



RENAULT  
PRO+

# Renault MASTER



October 2020



MASTER



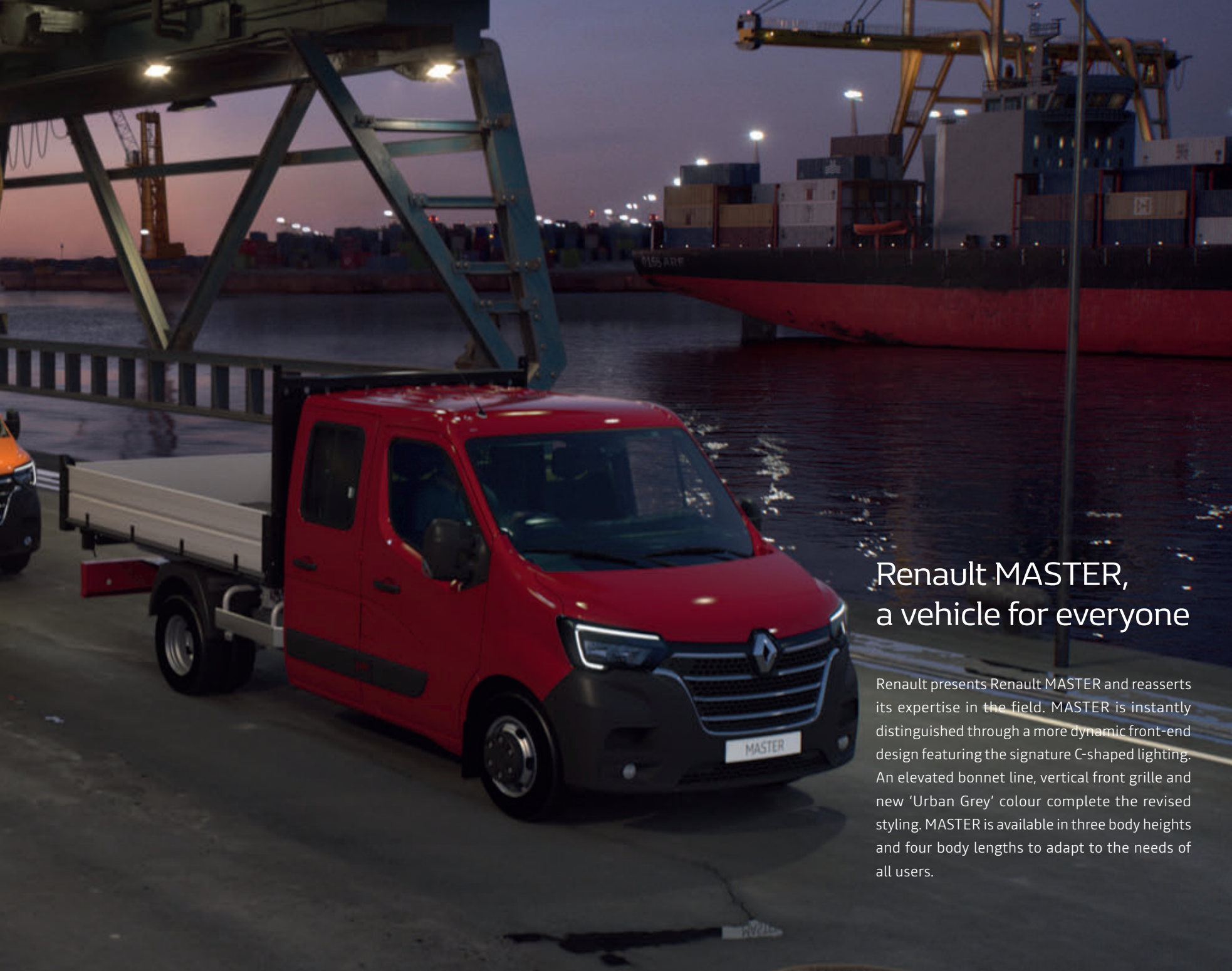

## Renault MASTER, a vehicle for everyone

Renault presents Renault MASTER and reasserts its expertise in the field. MASTER is instantly distinguished through a more dynamic front-end design featuring the signature C-shaped lighting. An elevated bonnet line, vertical front grille and new 'Urban Grey' colour complete the revised styling. MASTER is available in three body heights and four body lengths to adapt to the needs of all users.



**WINNER**  
LARGE VAN OF THE YEAR  
RENAULT MASTER



**WINNER**  
LCV OF THE YEAR  
RENAULT MASTER

## Driving has never been as comfortable

Professionals have tough and busy days; this is why the Renault MASTER cabin area has been designed to provide the comfort and practicality of a 'Mobile Office'. Packed with clever solutions, such as hidden laptop storage, that help to keep you connected on the go. (standard on Business+).







## Easy and secure loading

MASTER gives priority to practicality and efficiency. The rear doors can be opened 270° (optional), and the very low body sill makes it easier to load cumbersome items. Anchorage points (up to 12) secure the goods, and handles, ideally placed on the sides of the doors, save you effort in loading and unloading from the rear area. With its wide rear and side openings and optimum load volume (from 8 m<sup>3</sup> to 22 m<sup>3</sup>), MASTER adapts to the needs of all users.

In terms of security, the reinforced locks, factory fit alarm\* and 3-button key (standard on Business+) ensure that you work with complete peace of mind.

\*Alarm not standard on MASTER Z.E.













## Our profession, adapting to yours

MASTER is the tailor-made utility vehicle! A wide-range of body styles are available and include specific versions that meet unique needs: tippers (including the Aluminium Body version) and box vans. These variants are 100% Renault 'off-the-shelf' products produced and delivered as quickly as our standard vehicles.

It is also easy to convert a more bespoke vehicle using either a panel van, chassis (single or double cab) or platform cab with thanks to one of our many Renault approved converters across the UK.

For more details about our range of Off-the-shelf and Tailor Made accredited conversions please see our separate Conversions Range brochure.





1.

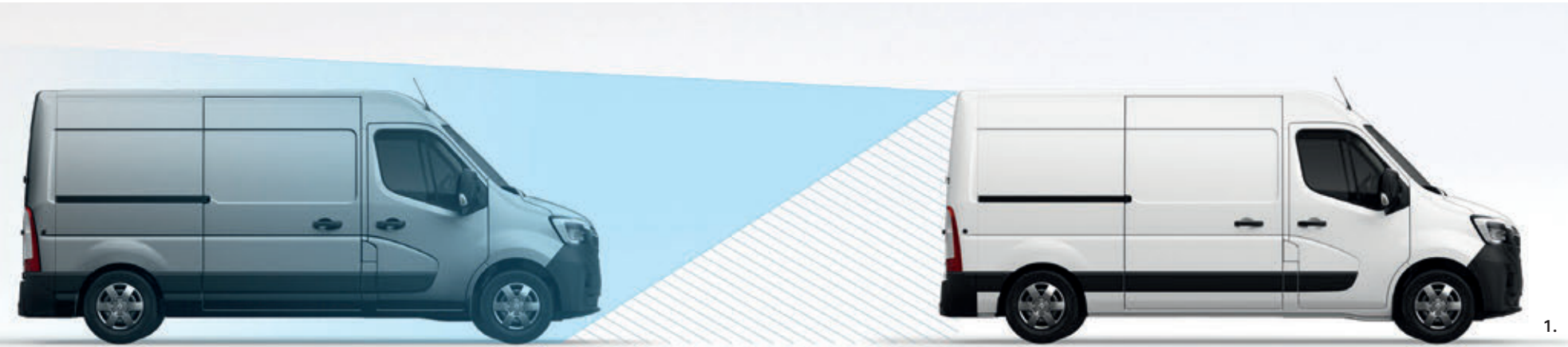

1.



# Performance and safety

In terms of driving, the increased power and torque offer greater comfort at low engine speed and more responsiveness at higher speed. The Renault MASTER engines help you save fuel through controlled consumption.

**Rear View Assist Camera:** The new driving assistance systems do everything to make your life easier. The "Rear View Assist", a Renault innovation, offers excellent rear view at mid and long distance for the best possible anticipation when driving\*.

**Blind spot warning:** MASTER can be fitted with a system that detects the presence of any vehicle in your blind spot. Active between 19 mph and 87 mph, a light signal alerts you immediately in the event of an obstacle and gives you an optimised side view.

**Side Wind Assist:** MASTER is fitted with a system that helps maintain its trajectory above 43 mph when it is subjected to strong side winds or when a vehicle is overtaking it.

**Automatic Emergency Braking System:** An active safety system able to detect moving or stationary vehicles. Automatic emergency braking is triggered and takes charge of braking if you react with a delay.

(1) Rear View Assist Camera (optional)

(2) Blind spot warning (optional)

(3) Side wind assist (standard)

(4) Advanced Emergency Braking System (optional)

\* Only when driving forward, does not function when vehicle is reversing.

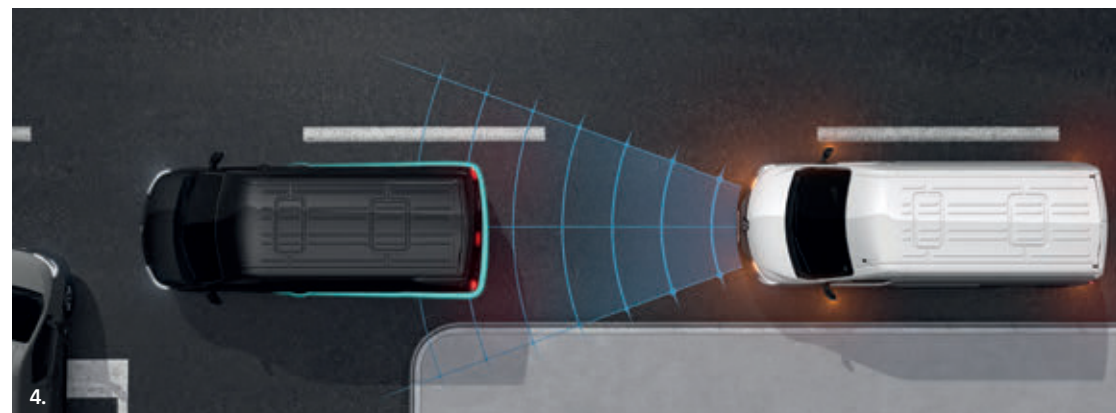
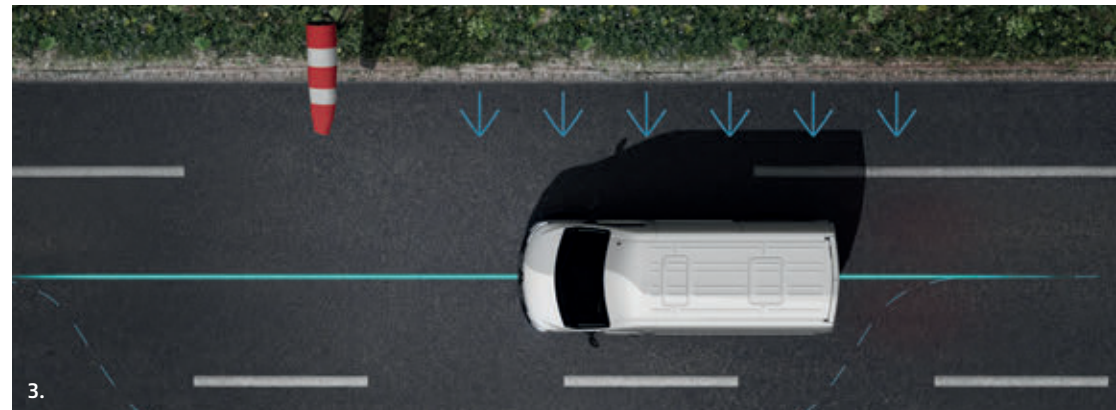



Front-wheel drive

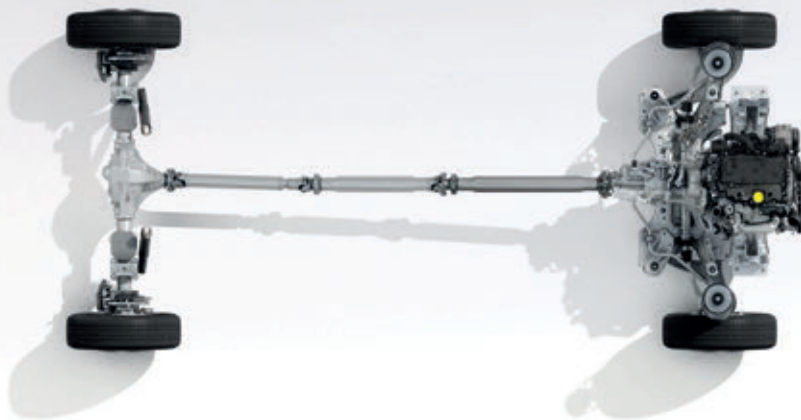

Rear-wheel drive

## Two versions available

Does your business involve the transport of heavy, cumbersome and fragile loads? MASTER has two technical choices to meet your requirements: a front-wheel drive version and a rear-wheel drive version. Which to choose? Each offers unrivalled road handling and has its own advantages. With a loading sill that is 13 mm lower, MASTER front-wheel drive\* and its 3 different lengths is perfect for payload and road transport. But if you're looking for traction as a priority, choose MASTER rear-wheel drive, capable of transporting the heaviest loads on the rear axle (in particular with twin wheels) and towing a trailer up to 3.5 t\*\*, on all types of terrain. After all, what better than to have a choice?

\* GVW up to 3.5t.

\*\* Twin wheel rear-wheel drive chassis version.











# Drive anywhere, in all weather

Do you drive all the time on different types of terrain and sometimes on bad roads? To meet occasional demands for enhanced traction and help you deal with poor driving conditions, Renault has developed new technology: Grip Xtend is the technology for you. Renault has developed this to improve the adaptability of your utility vehicle on difficult roads, such as unpaved or muddy tracks. The onboard computer recovers data from the wheels to optimise the vehicle's performance. When grip is lost, it adapts engine power to each wheel to improve the grip and manoeuvrability of the vehicle.

MASTER 4x4 (developed with Oberaigner) is there to help you. Thanks to the four-wheel drive system, its raised ground clearance and differential locking, slippery surfaces, rough roads, damp and steep slopes will no longer prevent you from working. In 2-wheel drive mode, it has an automatic rear differential lock which can be activated. It can also be activated in full 4-wheel drive mode with a front differential lock. The MASTER 4x4 suspension is raised by: 65 mm at the front/45 mm at the rear (twin wheels)/58 mm at the rear (single wheels). MASTER 4x4 also includes metal plate protection under the engine and under the body to protect vital components\*.

\* Optional on RWD versions

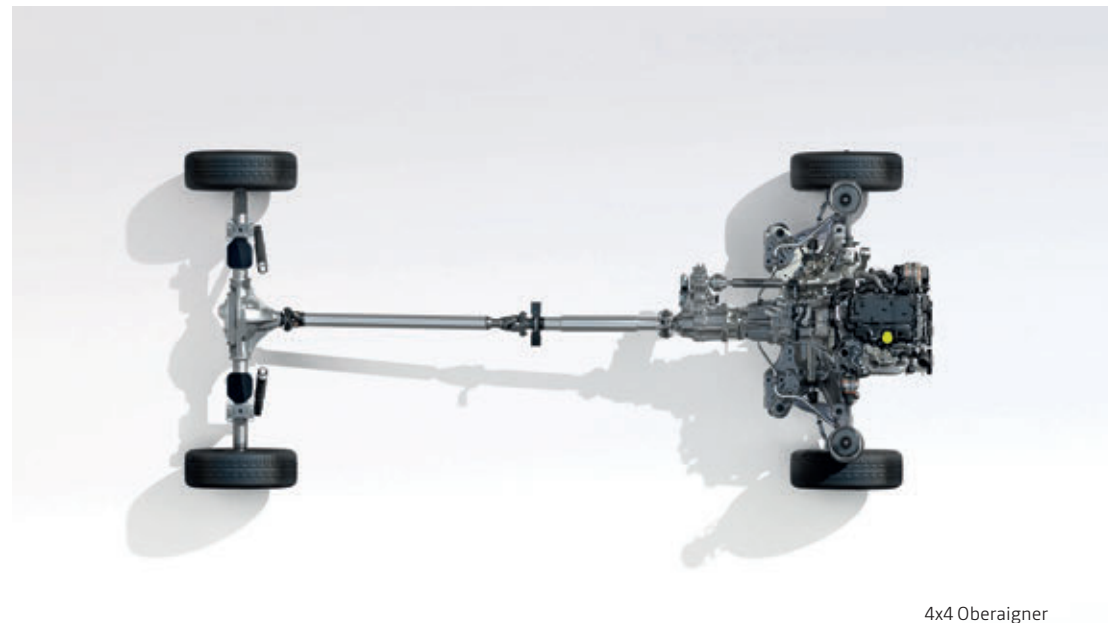
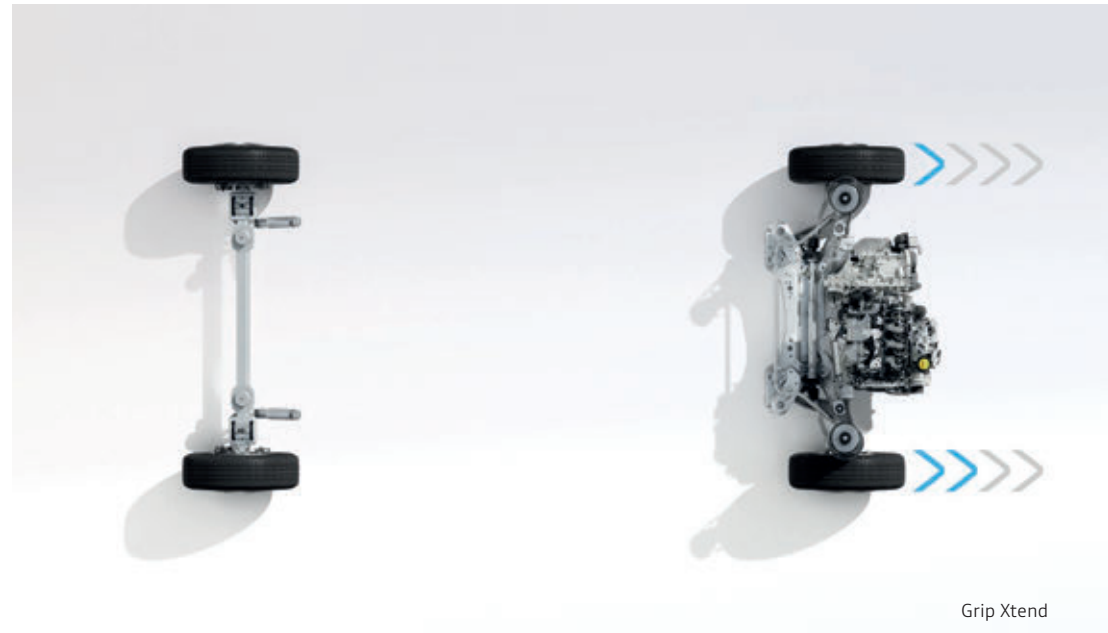







## Cutting emissions and your costs: the 100% electric MASTER Z.E.

Introducing the MASTER Z.E. – ultra low running costs, zero emissions whilst driving and 75 miles (WLTP\*\*\*), giving a real-world driving range of 75 miles in summer and 50 miles in winter. All that while maintaining the same dimensions as its diesel equivalents! The MASTER Z.E. has an impressive load capacity of up to 19m<sup>3</sup><sup>^</sup> and a payload that goes up to 1,425kg, plus all the extra benefits of owning an electric vehicle. Reduced road noise, no congestion charges\* and low running costs from less than 6.5p per mile\*\* prove that our MASTER Z.E. will not only be a great purchase for your fleet but also for your pocket!

\*Emission based congestion charges in ULEZ's including London Congestion Charge as of 2020. \*\*Less than 6.5p per mile calculated by (a) electricity charges (e.on Go Online 1 Year v18) rates for payment via monthly Direct Debit as of Sept 2018) and (b) a full recharge of the 33kWh battery giving £5 full recharge cost divide by the real world summer range in miles. \*\*\*WLTP figures shown are for comparability purposes; only compare figures with vehicles tested to the same technical procedures. The WLTP electric range shown has been achieved using the new (WLTP) test procedure. Figures obtained after the battery was fully charged. Actual real world driving results may vary depending on factors such as the starting charge of the battery, accessories fitted after registration, weather conditions, driving styles and vehicle load. Renault estimates average real world driving figures for this vehicle as 75 miles in summer and 50 miles in winter, depending on the factors above. ^ Load volume dependent on conversion





## Your 100% controlled driving range



MASTER Z.E. has 75 miles<sup>(1)</sup> of driving range in actual use thanks to its lithium-ion Z.E. 33 (33 kWh) battery. The 57 kW power unit offers a torque of 225 Nm and optimum driving comfort. A range of on-board technologies, such as regenerative braking (the battery recharges when the accelerator pedal is released or when the brake pedal is pressed) or the Eco mode (less abrupt acceleration and maximum speed of 50 mph), help optimise your driving range. You can charge your MASTER Z.E. in just 6 hours with a 32 A/7 kW Wallbox. The recharging flap located on the right-hand side of the vehicle, is easily accessible.

(1) Real-world driving range greater than 50 miles including the most severe use (high load, city centre driving with frequent stops and winter conditions). Actual consumption also depends on the equipment, the driving style of the driver and the elevation profile of the route.





**1. Regenerative braking.** The battery recharges when you take your foot off the accelerator or when you press on the brake pedal.

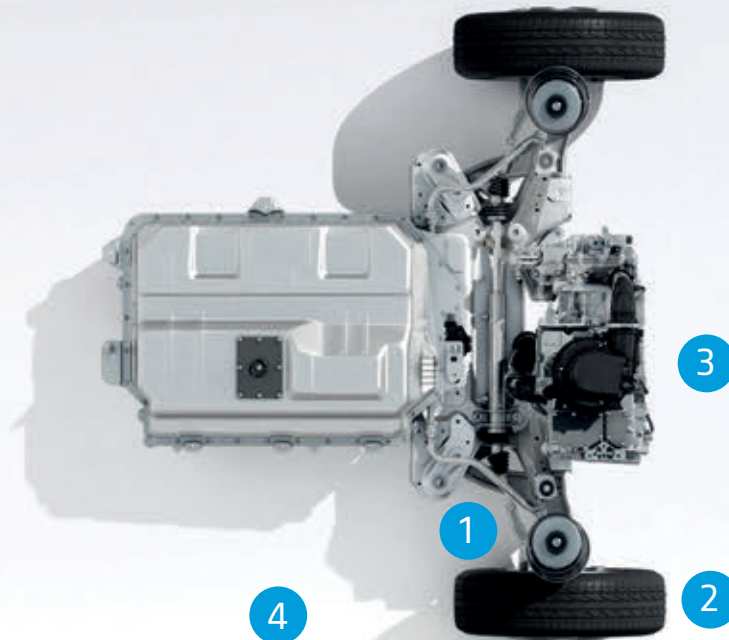

**2. Low consumption tyres.** Their low rolling resistance contributes to conserving your driving range without degrading your road-holding or braking ability.

**3. Eco mode.** When you activate this, you reduce the power output of the vehicle so that you can travel further (less abrupt acceleration and maximum speed of 50 mph).

**4. 7 kW charger.** Recharge the battery in just 6 hours with a 32 A/7 kW Wallbox. The recharging flap located on the right-hand side of the cab, is easily accessible.

# Charging your MASTER Z.E.

**KEY**  
 Driving Distance  Charging Time

**CHARGING AT HOME** – couldn't be easier to charge your MASTER Z.E. at home\*, just park your van, plug it in and go inside.

Multiple short journeys summer

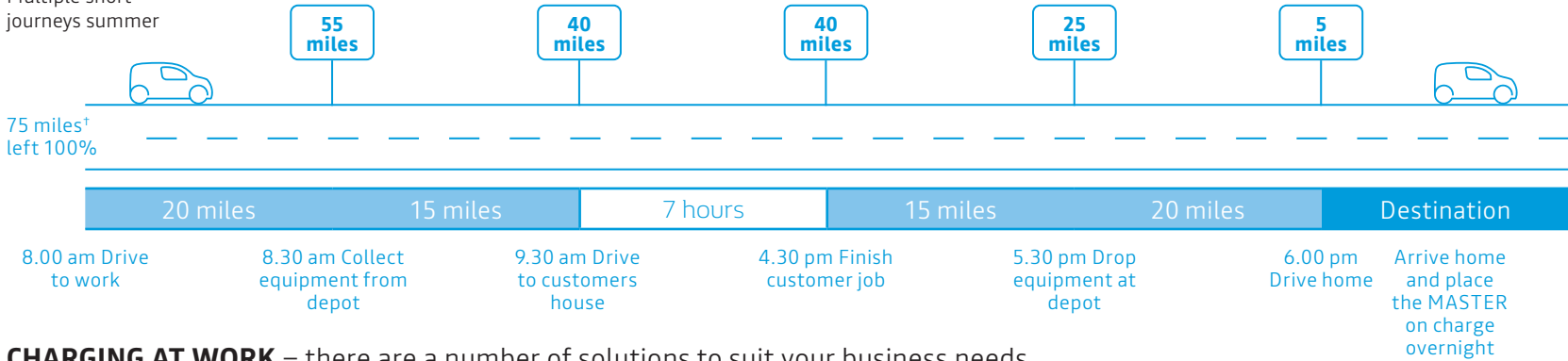

**CHARGING AT WORK** – there are a number of solutions to suit your business needs.

70 deliveries 30 mile route winter<sup>†</sup>

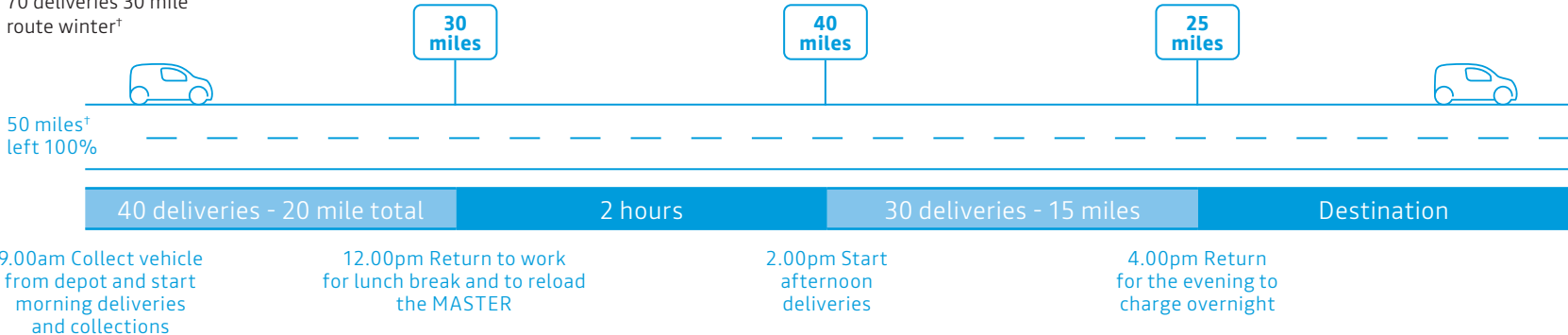

**OUT ALL DAY** – The MASTER Z.E. can keep going all day, especially on high stop and start routes.

90 delivery locations route summer<sup>†</sup> with 700kg starting load

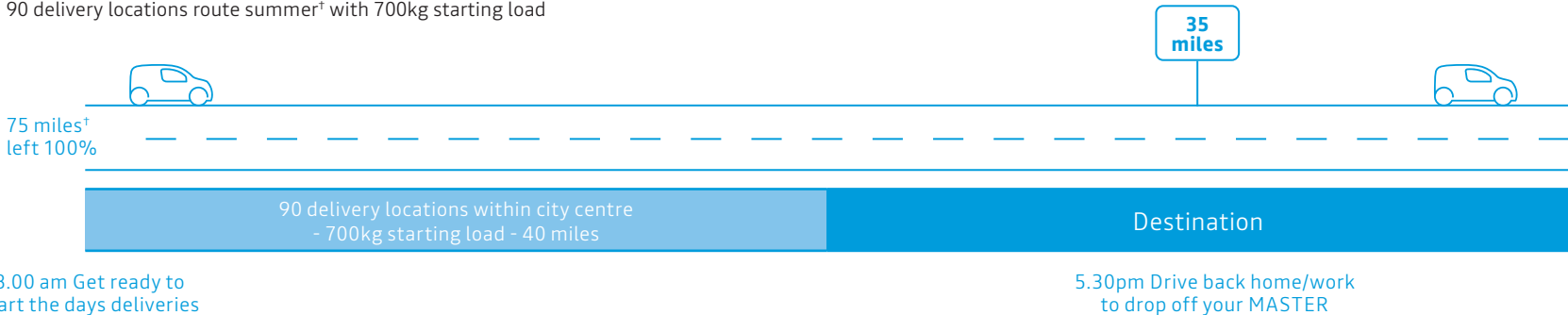

\* subject to off street parking and wall-box suitability.

<sup>†</sup> Figures shown are for comparability purposes; only compare figures with vehicles tested to the same technical procedures. There is a new test for electric range figures however the electric range figures shown are based on the outgoing (NEDC) test cycle. Figures obtained after the battery was fully charged. Actual real world driving results may vary depending on factors such as the starting charge of the battery, accessories fitted after registration, weather conditions, driving styles and vehicle load.



# Find the electric LCV that's right for you!

## Z.E. - Full purchase

To prevent you from the hassle of worrying about monthly plans, we provide you your MASTER Z.E. with batteries included.



No on-going monthly payments, just one simple payment.



No mileage limit.



Battery guarantee\* of 5 years / 62,000 miles, whichever comes first, this includes the battery performance guarantee to at least 70% of its original capacity.



Roadside assistance, breakdown only.

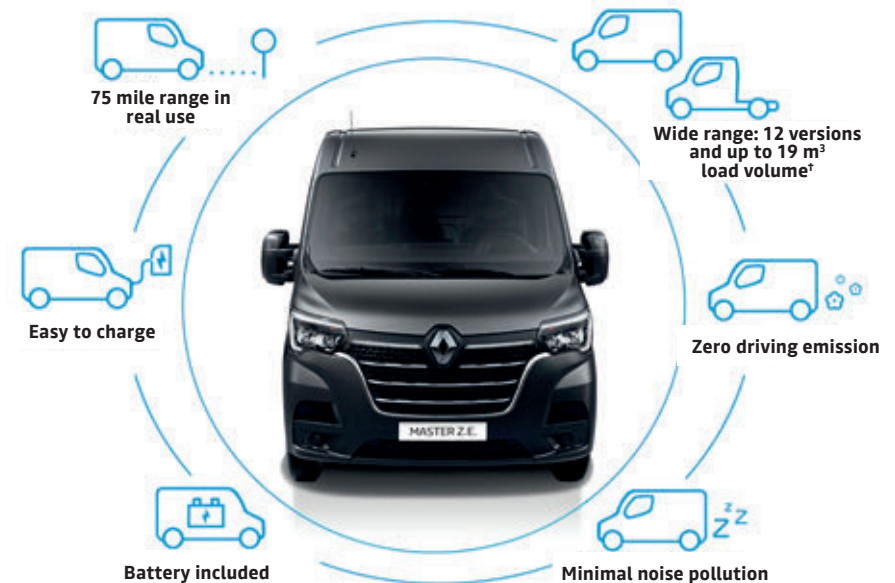

\*For full terms and conditions visit <https://www.cdn.renault.com/content/dam/Renault/UK/brand-and-editorial/Aftersales/ZE-warranty-2018.pdf>  
 ¹Requires conversion

## Charging solutions – options that suit your needs!

We offer you several charging solutions to make sure your vehicle is always ready to go!

Type of charger	Where to use it	Power required	Charging times (0-100%)	
Home (3-pin plug cable)*	Home / Office	2.3kW/10A	17 hours	Occasional slow charging. *Requires additional purchase of a EVSE cable.
	Home / Office	3.3kW/14A	12 hours	
Wallbox / Public charging point	Home / Office / On the go	3.7kW/14A	11 hours	Leaving the MASTER to charge overnight on a 3.7kW charger ensures that it will be ready for when you to begin your next day.  A standard charging time of 6 hours means your vehicle is ready to go when you are.
	Home / Office / On the go	7kW	6 hours	
Public charging point	On the go	22kW	6 hours	
	On the go	43kW	6 hours	

# Colours

---

Mineral White (S)



Urban Grey (S)



Carmen Red (S)



Orange (S)





Lemon Yellow (S)



Persian Blue (S)



Caribbean Blue (S)



Star Grey (M)



Tempest (M)



Pearl Black (M)



	Mineral White (QNG)	Urban Grey (KPW)	Carmen Red (719)	Orange (031)	Lemon Yellow (396)	Persian Blue (RNQ)	Caribbean Blue (423)	Star Grey (KNH)	Tempest (J47)	Pearl Black (676)
Business	●	●	●	●	●	●	●	○	○	○
Business+	●	●	●	●	●	●	●	○	○	○

● = Standard (therefore no cost) ○ = Optional

(S) Solid paint (M) Metallic paint

Every effort has been made to ensure that the information, descriptions, and images were correct at the time of publication however images may not always reflect the exact version selected. It should be noted that limitations on screen do not permit the subtle paintwork shades on this page to be shown with absolute accuracy.

# Standard features



16" steel wheels



Kaleido



## BUSINESS

### Technology

- Radio with DAB, Bluetooth and USB
- 6-speed gearbox
- ESC (Electronic Stability Control) with Grip Xtend, Hill Start Assist and Trailer Swing Assist
- Trip computer - multi-functional

### Interior

- Closed glove box
- 2 cup holders on centre console
- Driver's seat - height adjustable, lumbar adjustment and armrest
- Steering wheel - height adjustment
- Electric front windows
- Passenger bench seat
- Overhead parcel shelf
- Kaleido - dark grey upholstery

### Exterior

- Left side loading door - unglazed
- 80-litre fuel tank
- 22-litre AdBlue tank
- C-Shaped DRL's (Daytime running lights)
- Door mirrors - electric adjustment, heated
- 16" steel wheels with small wheel stylers
- Rear doors - unglazed, 180°
- Spare wheel

### Safety and security

- Full-steel bulkhead
- ABS with EBD (Electronic Brake force Distribution)
- Alarm (excluding MASTER Z.E.)
- Electronic immobiliser
- Remote central locking (foldable 2 button key)
- Airbag - driver
- Seatbelts - 3 point height-adjustable seatbelts with pretensioners

- 4 disc brakes
- Automatic headlights and wipers
- Deadlocking
- Rear running board and handles
- Anchorage points : L1 - 6, L2 - 8, L3 - 10, L4 - 12
- Weight allowed per anchorage point: approximately 500kg'

### Specific Z.E. Equipment

- Z.E. charging socket (right-hand side)
- Z.E. Voice: emits a distinctive range of sounds signalling that the vehicle is moving
- Engine speed limiter 62 mph
- Standard charging cable 32A (IEC 62196 - Type 2 Mennekes) 6m

### Crew Van adds

- 2nd row of 4 passenger seats
- Integrated storage nets and cup holders
- Single passenger seat on LWB versions
- Left and right side loading doors - glazed
- Bulkhead - full-steel with glazing

### RWD additional equipment

- Rear step
- Side marker lights (LWB or MWB with extended overhang only)
- Lane departure warning system (4.5T versions only)
- Engine speed limiter 56mph (to meet legal requirement) - 4.5T version only
- Digital tachograph (4.5T version only) and CAN interface unit



# Standard features

---



16" steel with large wheel stylers



Kaleido



## **BUSINESS+** (in addition to BUSINESS)

### **Interior**

- Manual air conditioning and pollen filter
- Electric front windows - driver's side one touch descending
- Driver's seat - fully adjustable suspension type (panel vans only, not crew vans)
- Interior chrome trim
- Pivoting seatback table with dual split underseat storage compartment
- 12V power socket in load area

### **Exterior**

- 16" steel wheels with large wheel stylers
- Chrome trim on front grille

### **Safety and Security**

- Wide view mirror
- Rear parking sensors

# Standard features - Conversions

## BUSINESS



Platform cab



Chassis cab



Dropside



Tipper

## Chassis Cab and Platform Cab

### Technology

- Radio with DAB, Bluetooth and USB
- 6-speed gearbox
- ESC (Electronic Stability Control) with Grip Xtend, Hill Start Assist and Trailer Swing Assist
- Trip computer - multi-functional

### Interior

- Closed glove box
- 2 cup holders on central console
- Driver's seat - height adjustable, lumbar adjustment and armrest
- Steering wheel - height adjustment
- Electric front windows
- Passenger bench seat
- Overhead parcel shelf
- Kaleido - dark grey upholstery

### Exterior

- 80-litre fuel tank
- 22-litre AdBlue tank
- C-Shaped DRL's (Daytime running lights)
- Door mirrors - electric adjustment, heated
- 16" steel wheels with small wheel stylers
- Side marker lights wiring (on LL, MLL and LLL versions only)
- Spare wheel

### Safety and security

- Full-steel bulkhead
- ABS with EBD (Electronic Brake force Distribution)
- Automatic headlights and wipers
- Electronic immobiliser
- Alarm (excluding MASTER Z.E.)
- Remote central locking (foldable 2 button key)
- Airbag - driver
- Bulkhead - full-steel with glazing (full-steel bulkhead on Platform Cab and Luton Low Loader, unglazed)
- 4 disc brakes
- Deadlocking

### RWD adds

- Digital tachograph (4.5T versions only) and CAN interface unit
- Engine speed limiter 56mph (to meet legal requirement) (4.5T version only)

### Double cab adds

- Second row of 4 passenger seats
- Single passenger seat on all Factory Tippers and Twin Rear Wheel Dropsides only\*\*
- Left and right rear lateral doors - glazed

### Dropside adds

- Hot-galvanised steel front side panel and platform
- Anti-slip wooden floor
- Anchorage points in loading area (6 to 8 depending on version)  
Weight allowed per anchorage point: approximately 500kg
- Folding and removable aluminium side and rear panels (400mm high)
- Foldaway step on rear side panel
- Steel cab protecting grid with ladder/long object rack
- Rear corner pillars
- Version available with a tail lift as standard (Del 500kg mesh platform tail lift with 915mm platform and fixed leading edge)
- Additional options available on request via VFS

### Tipper adds

- Rear tipping "Scattolini" body (45°)
- Hot-galvanised steel loading deck (2 mm thick)
- Aluminium side and rear panels (400 mm high)
- Aluminium cab protecting grid with ladder/long object rack

### Aluminium Tipper adds (different from Factory Steel Tipper)

- Tipper sub-frame manufactured from aluminium, constructed using "state of the art" robotic aluminium Spot and TiG welding
- Aluminium Cab Protector
- Aluminium / Composite Tool Pod fitted as standard on single cab LL versions
- Additional options available on request via VFS

### Luton Box Van adds

- 11 mm thick GRP side panels, with fibreglass roof skin on a 65 mm alloy frame
- 15 mm thick wisdeck birch floor
- Luton front providing over-the-cab storage fitted as standard
- Rear doors - roller shutter on alloy frame with rear columns designed to support column mounted tail lift
- Version available with a tail lift as standard (Del 500kg column tail lift with 815mm alloy platform and fixed leading edge one-two button external control)
- Additional options available on request via Truckcraft Bodies

### Specific Z.E. Equipment

- Z.E. charging socket (right-hand side)
- Z.E. Voice: emits a distinctive range of sounds signalling that the vehicle is moving
- Engine speed limiter 62 mph
- Standard charging cable 32A (IEC 62196 - Type 2 Mennekes) 6m

For more details about our range of Off-the-shelf and Tailor Made accredited conversions please see our separate Conversions Range brochure

\*For compatible devices, please refer to [www.Renault.co.uk/services/multimedia/bleetooth-compatibility](http://www.Renault.co.uk/services/multimedia/bleetooth-compatibility)

\*\*Passenger bench not available





# Upholstery and wheel trims



**Kaleido black and grey fabric**  
Standard on Business and Business+

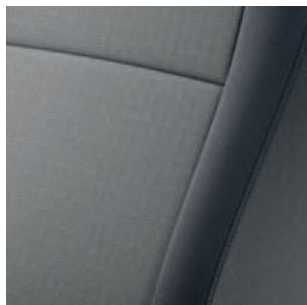

**Black and dark carbon Kompo fabric**  
Optional (Not available on Business+ and RWD)

## Wheels



**16" Steel wheels with small wheel stylers**  
Standard on Business



**16" Steel wheels with large wheel stylers**  
Standard on Business+



**16" Alloy wheels**  
Optional (FWD only)

## Tyres

TYPE	Euro 6d-Temp emissions standards			Euro 6VI emissions standards				Z.E.	
	SUMMER		ALL WEATHER	SUMMER		ALL WEATHER		SUMMER	
GVW/Transmission	2.8 t, 3.3 t and 3.5 t/ Front-wheel drive		2.8 t, 3.3 t and 3.5 t/ Front-wheel drive	3.5 t/ Front-wheel drive	3.5 t/ Single wheel rear-wheel drive	3.5 t and 4.5 t/ Twin wheel rear-wheel drive	2.8 t, 3.3 t and 3.5 t/ Front-wheel drive	3.5 t and 4.5 t/ Twin wheel rear-wheel drive	3.1 t/ Front-wheel drive
Tyres	225/65R16 Bridgestone Duravis	225/65R16 Continental Vancontact	225/65R16 Continental Vancontact 4 Seasons	225/65R16 Continental Vancontact	235/65R16 Michelin Agilis	195/75R16 Continental Vancontact	225/65R16 Continental Vancontact 4 Seasons	195/75R16 Continental Vancontact 4 Seasons	215/65R16 Continental Vancontact
Consumption class	A		B	A	B	B	B	E	A
Grip class on wet ground	A		A	A	A	A	A	C	A
Noise level	72 dB		73 dB	72 dB	72 dB	72 dB	73 dB	72 dB	72 dB



# The range

---

## Closed transport

You have a wide range of different needs, which can be met by the wide variety of interior fittings and length x height combinations of Renault MASTER, with a loading volume of between 8 and 20 m<sup>3</sup>.



FWD Panel van



Crew van



RWD Panel van



Box van



Tipper



Dropside



Platform cab



Chassis cab

## Conversions

Renault MASTER is available in a number of versions, including Tipper, Chassis cab or Platform cabs which are ideal for a number of different conversions.

# Dimensions

## Front-wheel drive panel van

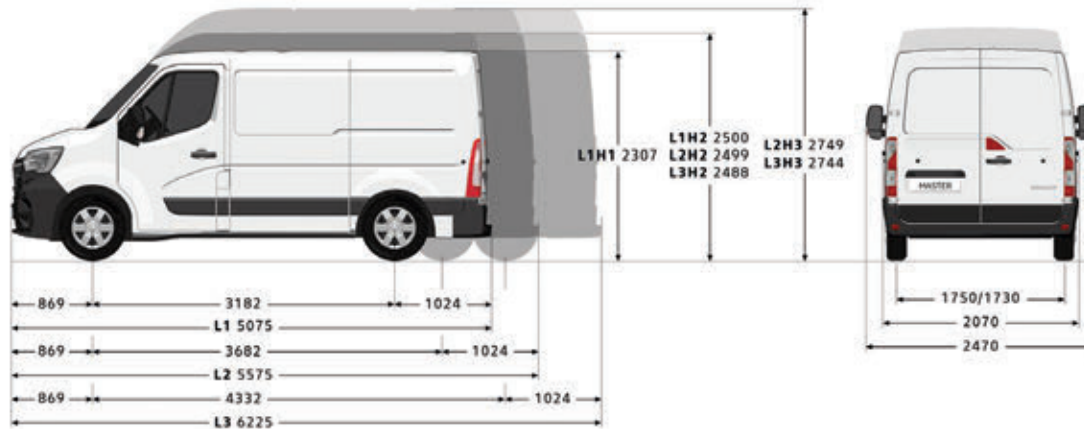

## WEIGHTS AND LOADS Front-wheel drive panel van (kg)

	Effective volume (m <sup>3</sup> )		GVW
			<b>3.1 t</b> <b>MASTER Z.E</b>
L1H1	8	Min. kerb weight <sup>(1)</sup>	2,022
		Max. payload <sup>(2)</sup>	1,078
		Max. load on front axle	1,550
		Max. load on rear axle	1,650
L1H2	9	Min. kerb weight <sup>(1)</sup>	2,050
		Max. payload <sup>(2)</sup>	1,050
		Max. load on front axle	1,650
		Max. load on rear axle	1,900
L2H2	10.8	Min. kerb weight <sup>(1)</sup>	2,094
		Max. payload <sup>(2)</sup>	1,006
		Max. load on front axle	1,700
		Max. load on rear axle	1,900
L3H2	13	Min. kerb weight <sup>(1)</sup>	2,175
		Max. payload <sup>(2)</sup>	925
		Max. load on front axle	1,700
		Max. load on rear axle	1,900

## WEIGHTS AND LOADS Front-wheel drive panel van (kg)

	Effective volume (m <sup>3</sup> )		GVW					
			2.8 t Business	2.8 t Business+	3.3 t Business	3.3 t Business+	3.5 t Business	3.5 t Business+
L1H1	8	Min. kerb weight <sup>(1)</sup>	1,927	1,952	-	-	-	-
		Max. payload <sup>(2)</sup>	873	848	-	-	-	-
L1H2	9	Min. kerb weight <sup>(1)</sup>	-	-	-	-	1,949	-
		Max. payload <sup>(2)</sup>	-	-	-	-	1,551	-
		Max. load on front axle	1,550	1,550	-	-	1,850	-
		Max. load on rear axle	1,650	1,650	-	-	2,100	-
L1H1/L1H2		Max. towing weight (braked/unbraked)	2,500/750			2,500/750		
		Turning circle, kerb to kerb	12.0 m			12.0 m		
		Turning circle, wall to wall	12.5 m			12.5 m		
L2H2	10.8	Min. kerb weight <sup>(1)</sup>	-	-	2,021	2,046	2,021	2,046
		Max. payload <sup>(2)</sup>	-	-	1,279	1,254	1,479	1,454
L2H3	12.3	Min. kerb weight <sup>(1)</sup>	-	-	-	-	2,046	-
		Max. payload <sup>(2)</sup>	-	-	-	-	1,454	-
		Max. load on front axle	-	-	1,850	1,850	1,850	1,850
		Max. load on rear axle	-	-	2,100	2,100	2,100	2,100
L2H2/L2H3		Max. towing weight (braked/unbraked)	-			2,500/750		
		Turning circle, kerb to kerb	-			13.6 m		
		Turning circle, wall to wall	-			14.1 m		
L3H2	13	Min. kerb weight <sup>(1)</sup>	-	-	-	-	2,116	2,141
		Max. payload <sup>(2)</sup>	-	-	-	-	1,384	1,359
L3H3	14.8	Min. kerb weight <sup>(1)</sup>	-	-	-	-	2,123	-
		Max. payload <sup>(2)</sup>	-	-	-	-	1,377	-
		Max. load on front axle	-	-	-	-	1,850	1,850
		Max. load on rear axle	-	-	-	-	2,100	2,100
L3H2/L3H3		Max. towing weight (braked/unbraked)	-			2,500/750		
		Turning circle, kerb to kerb	-			15.7 m		
		Turning circle, wall to wall	-			16.2 m		

## INTERIOR DIMENSIONS Front-wheel drive panel van (mm)

	L1H1	L1H2	L2H2	L2H3	L3H2	L3H3
<b>Loading area</b>						
Effective length	2,583		3,083		3,733	
Effective length at 1.1 m	2,530		3,030		3,680	
Effective width			1,765			
Width between wheel arches			1,380			
Effective height	1,700	1,894	2,144	1,894	2,144	
<b>Sliding side door(s)</b>						
Width of sliding side door(s)	1,050			1,270		
Height of sliding side door(s)	1,581			1,780		
<b>Rear door</b>						
Width (169 mm from floor)			1,580			
Entrance height	1,627		1,820			
Loading sill (min./max.)	546/564	544/563	545/562	543/560	543/557	542/555
Ground clearance (min)	182	174	173	172	169	

(1) The kerb weight is the weight of the vehicle without the driver and with the fuel tank filled to 90%. This weight may vary according to the equipment and engine (by up to 330 kg). (2) The payload is calculated as the difference between the Gross Vehicle Weight (GVW) and the kerb weight.

## Rear-wheel drive panel van

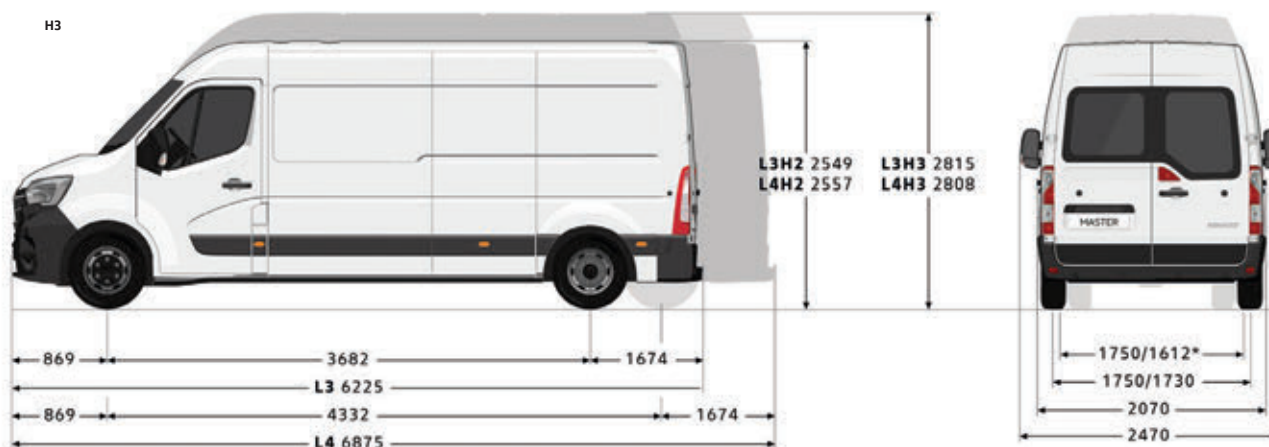

\* Twin wheels.

### WEIGHTS AND LOADS Rear-wheel drive panel van (kg)

	Effective volume (m <sup>3</sup> )		GVW		
			3.5 t SW	3.5 t TW	4.5 t TW
<b>L2H2 Long Overhang</b>	12.4	Min. kerb weight <sup>(1)</sup>	2,343	2,399	-
		Max. payload <sup>(2)</sup>	1,157	1,101	-
<b>L3H2 Long Overhang</b>	14.9	Min. kerb weight <sup>(1)</sup>	2,343	2,439	2,439
		Max. payload <sup>(2)</sup>	1,157	1,061	2,061
<b>L3H3 Long Overhang</b>	17	Min. kerb weight <sup>(1)</sup>	2,390	2,510	2,510
		Max. payload <sup>(2)</sup>	1,110	990	1,990
<b>L2H2 Long Overhang/L3H2 Long Overhang SW/L3H3 Long Overhang SW</b>		Max. load on front axle	1,850		
		Max. load on rear axle	2,300	2,445	3,145
		Max. towing weight (braked/unbraked)	2,500/750		
		Turning circle, kerb to kerb 14.1 m	13.6-15.7		
		Turning circle, wall to wall 13.6 m	14.1-16.2		

(1) The kerb weight is the weight of the vehicle without the driver and with the fuel tank filled to 90%. This weight is given for the basic version and may vary according to the equipment and engine (by up to 330 kg). (2) The payload is calculated as the difference between the Gross Vehicle Weight (GVW) and the kerb weight.

### INTERIOR DIMENSIONS Rear-wheel drive panel van (mm)

	L2H2 Long overhang SW	L2H2 Long overhang TW	L3H2 Long overhang SW	L3H2 Long overhang TW	L3H2 Long overhang SW	L3H3 Long overhang TW
<b>Loading area</b>						
Effective length	3,733		4,383			
Effective length at 1.1 m	3,680		4,330			
Effective width	1,765					
Width between wheel arches	1,380	1,080	1,380	1,080	1,380	1,080
Effective height	1,798		1,798		2,048	
<b>Sliding side door(s)</b>						
Width of sliding side door(s)	1,270					
Height of sliding side door(s)	1,684					
<b>Rear door</b>						
Width (169 mm from floor)	1,580					
Entrance height	1,724					
Loading sill (min./max.)	674/696	706/724	682/704	701/717	680/702	700/715
Ground clearance (min)	197	181	167			

SW: single wheels. TW: twin wheels.



# Dimensions

## Crew van

FRONT-WHEEL DRIVE

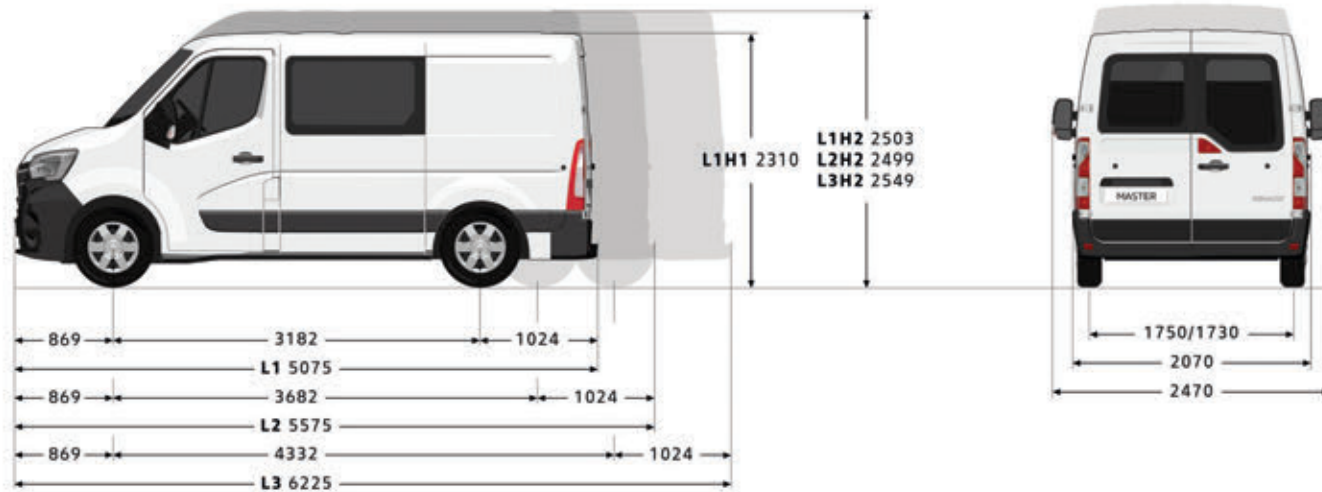

### WEIGHTS AND LOADS Crew van (kg)

	Max. payload	Effective volume m <sup>3</sup>
<b>GVW</b>	<b>3.5 t</b>	
L2H2 FWD Business	1,274	6.9
L3H2 FWD Business	1,180	9
L2H2 FWD Business+	1,249	6.9
L3H2 FWD Business+	1,155	9

SW: single wheels. TW: twin wheels.

### INTERIOR DIMENSIONS Crew van (mm)

	Front-wheel drive	
	L2H2	L3H2
<b>Loading area</b>		
Effective length at 0.4 m	2,175	2,825
Effective length at 1 m	1,990	2,640
Effective width	1,765	
Width between wheel arches	1,380	1,080
Effective height	1,894	1,798
<b>Sliding side door(s)</b>		
Width of sliding side door(s)	1,270	

### INTERIOR DIMENSIONS Crew van (mm) (continued)

	Front-wheel drive	
	L2H2	L3H2
Height of sliding side door(s)	1,780	1,684
<b>Rear door</b>		
Width at the lower part	1,580	
Height	1,820	1,724
Loading sill (min./max.)	545/562	543/557
Ground clearance	174	172

SW: single wheels. TW: twin wheels.

## Luton Box Van

### FRONT-WHEEL DRIVE

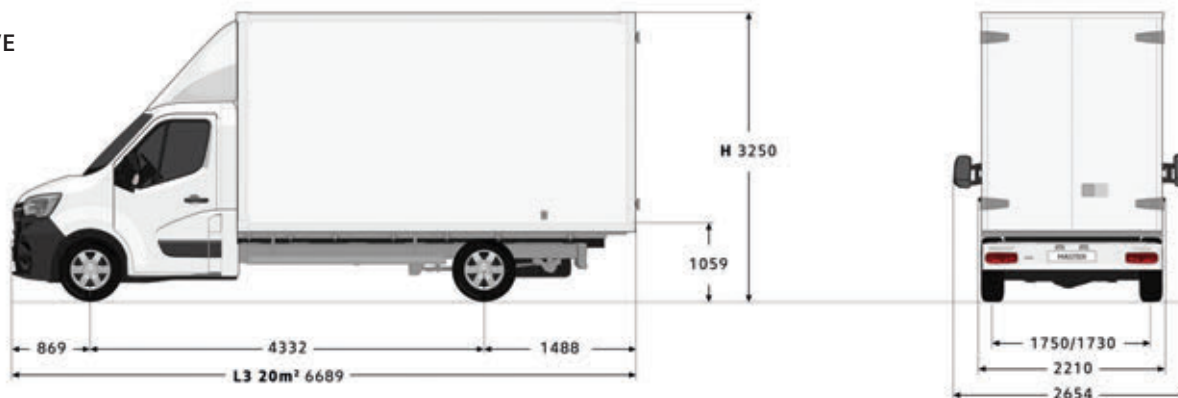

### REAR-WHEEL DRIVE

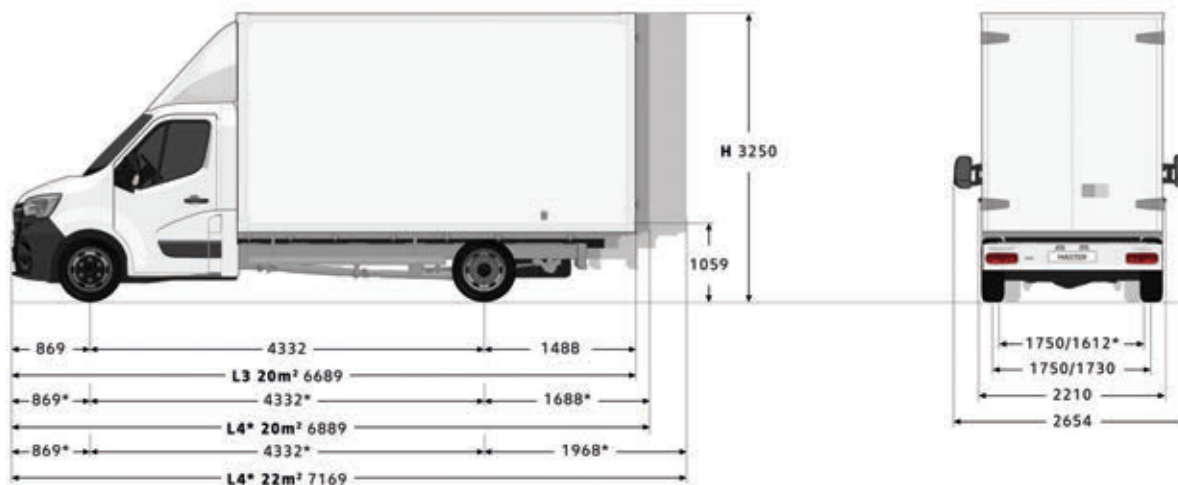

\* Twin wheels.

### WEIGHTS AND LOADS Box van (kg)

	Max. payload (kg)	Effective volume m <sup>3</sup>
<b>GVW</b>	<b>3.5t</b>	
L3 Front-wheel drive 20m <sup>3</sup>	1,204	20.1
L3 SW Rear-wheel drive 20m <sup>3</sup>	1,061	20.1
L4 TW Rear-wheel drive 22m <sup>3</sup>	902	21.7

SW: single wheels. TW: twin wheels.

### INTERIOR DIMENSIONS Box van (mm) (cont.)

	Front/Rear-wheel drive box van	
	20 m <sup>2</sup> on L3	22 m <sup>2</sup> on L4
Box van module		
Effective length	4,170	4,650
Effective width		2,220
Effective height		2,200

### INTERIOR DIMENSIONS Box van (mm)

	Front/Rear-wheel drive box van	
	20 m <sup>2</sup> on L3 (19.6m <sup>3</sup> )	20 m <sup>2</sup> on L4 (20.3m <sup>3</sup> )
Rear door		
Width		2,105
Height		2,165

# Dimensions

## Tipper

### FRONT-WHEEL DRIVE

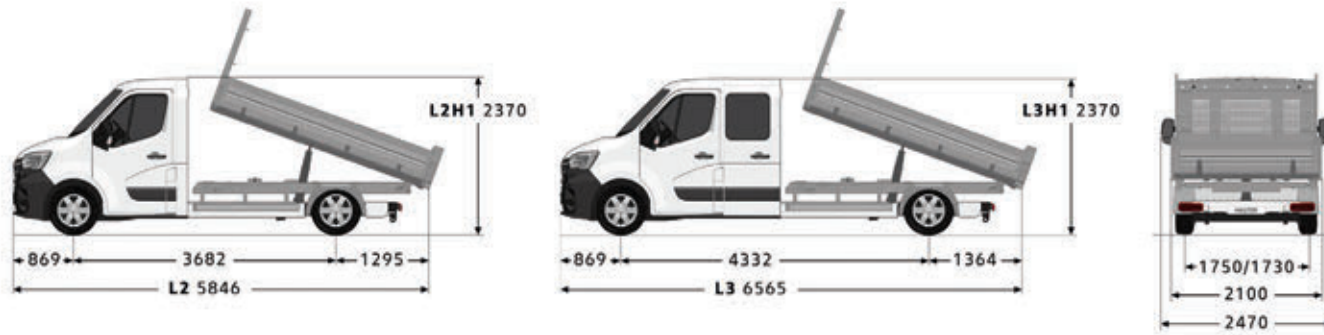

### REAR-WHEEL DRIVE

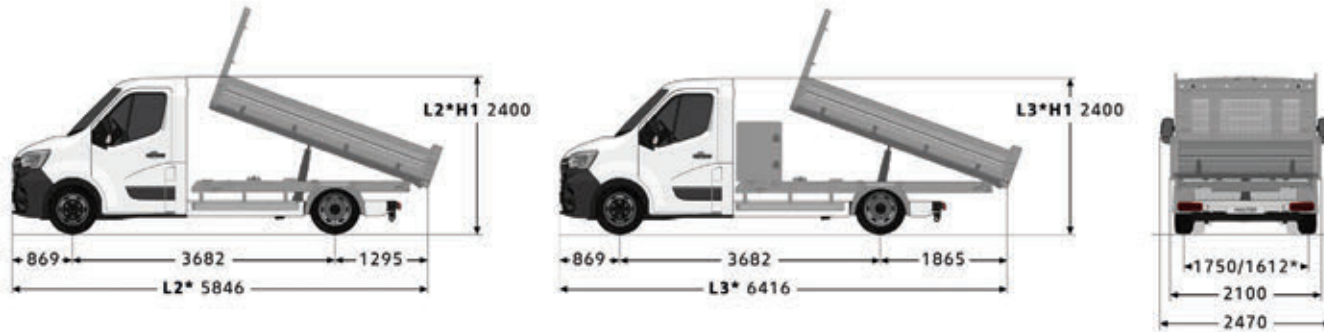

\* Twin wheels.

### WEIGHTS AND LOADS Tipper (kg)

	Single cab	Double cab
	Max. payload	
<b>GVW</b>	<b>3.5 t</b>	<b>3.5 t</b>
L2 Front-wheel drive with 3.3 m Tipper	1,217	-
L2 SW Rear-wheel drive with 3.3 m Tipper	1,104	-
L2 TW Rear-wheel drive with 3.3 m Tipper	934	-
L3 TW Rear-wheel drive with 3.2 m Tipper + boot	820	-
Double cab L3 SW Rear-wheel drive with 3.3 m Tipper	-	890
Double cab L2 Long Overhang TW Rear-wheel drive with 3.2 m Tipper	-	825*

### DIMENSIONS Tipper (mm)

	Single cab Tipper				Double cab Tipper	
	3.3 m		3.2 m + boot		3.3 m	
	L2		L3		L3	
	Front-wheel drive	Rear-wheel drive			Rear-wheel drive	
	SW	SW	TW	TW	SW	TW
Effective length		3,205		3,105	3,205	3,105
Effective width		2,040				
Side panel height		400				
Euro pallet capacity		6		5	6	5
Max. rear loading sill		1,020		1,080		1,080

Side panel thickness: 20 mm. Flatbed thickness: 2.5 mm. SW: single wheels. TW: twin wheels.



# Dropside

## FRONT-WHEEL DRIVE

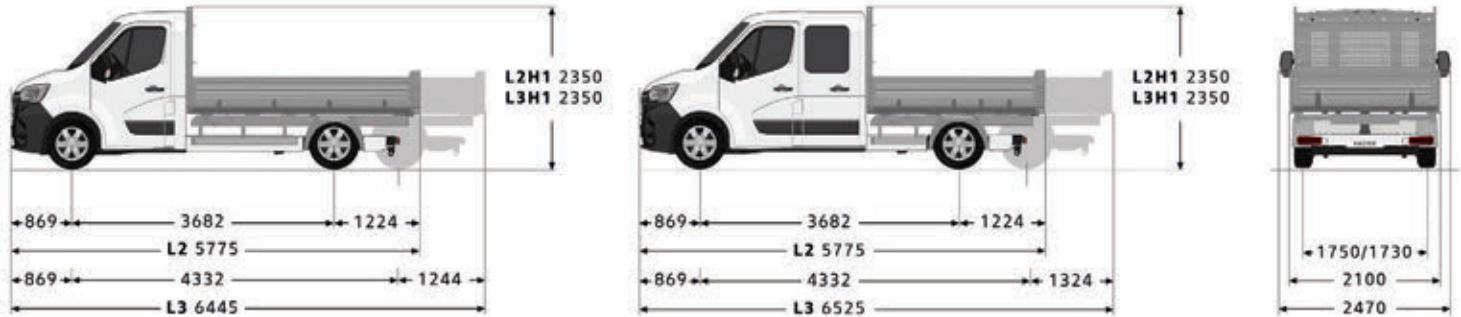

## REAR-WHEEL DRIVE

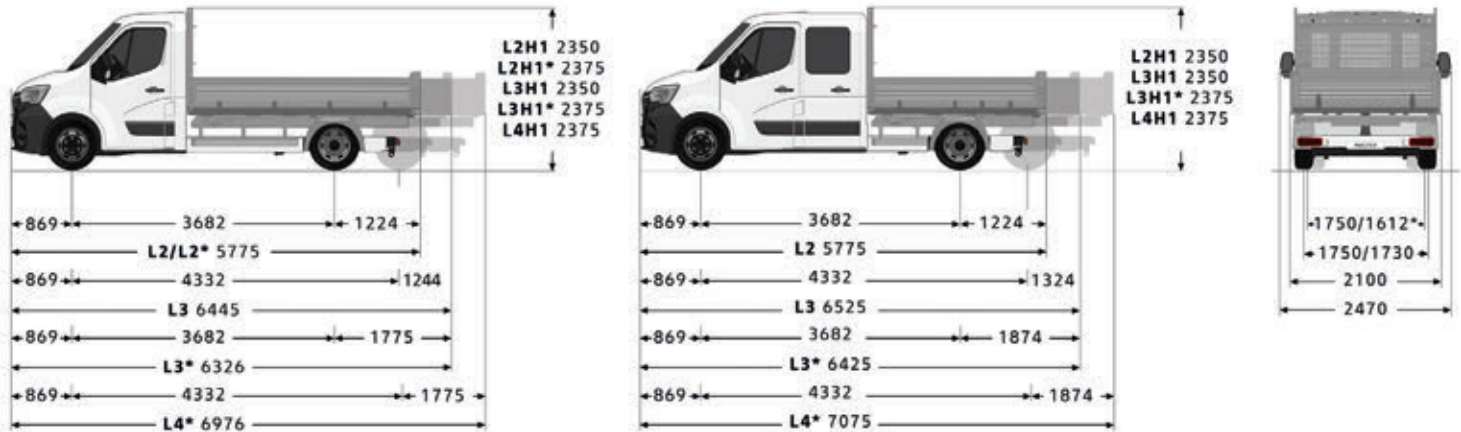

\* Twin wheels.

## WEIGHTS AND LOADS Dropside (kg)

	Single cab	Double cab
	Max. payload	
GVW	3.5t	3.5t
L2 FWD	1,401	-
L2 SW RWD	1,189	-
L2 TW RWD	1,087	-
L3 FWD	1,328	1,208
L3 SW RWD	1,185	1,067
L2 Long Overhang TW RWD	1,036	946
L3 Long Overhang TW RWD	995	852

SW: single wheels. TW: twin wheels.

## DIMENSIONS Dropside (mm)

	Single cab								Double cab							
	L2				L3		L2 Long overhang		L3 Long overhang		L3		L2 Long overhang		L3 Long overhang	
	Front-wheel drive	Rear-wheel drive		Front-wheel drive	Rear-wheel drive		Rear-wheel drive		Front-wheel drive	Rear-wheel drive		Front-wheel drive	Rear-wheel drive		L3 Long overhang	
		SW	TW		SW	TW	SW	TW		SW	TW		SW	TW		
Effective length	3,170		3,840		3,720		4,370		3,170		3,070		3,720			
Effective width	2,040															
Side panel height	400															
Euro pallet capacity	5				7		8		5		7					

Side panel thickness: 20 mm. Flatbed thickness: 3 mm. SW: singles wheels. TW: twin wheels.

# Dimensions

## Chassis single cab

### FRONT-WHEEL DRIVE

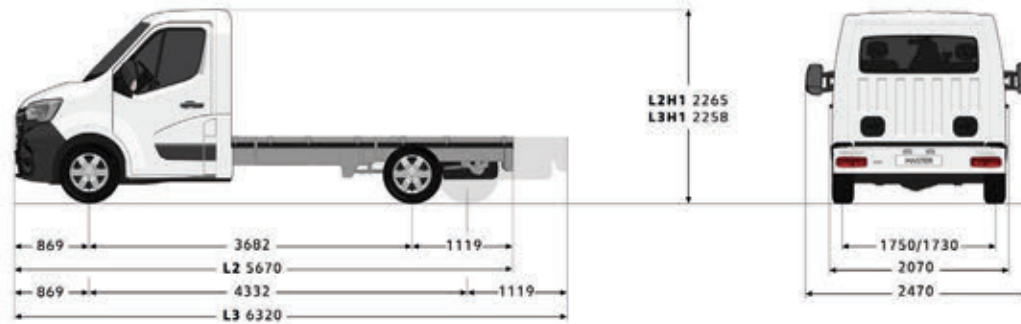

### REAR-WHEEL DRIVE

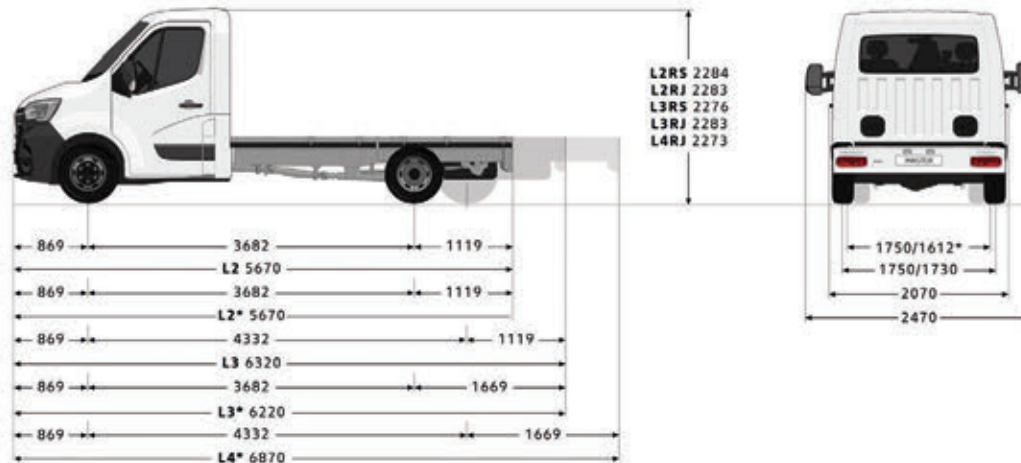

\* Twin wheels.

### WEIGHTS AND LOADS Chassis single cab (kg)

	Front-wheel drive			Rear-wheel drive						
	L2	L3	L2 SW	L2 TW	L3 SW	L2 Long overhang TW	L2 Long overhang TW	L3 Long overhang TW	L3 Long overhang TW	
<b>GVW</b>	<b>3.5t</b>	<b>3.5t</b>	<b>3.5t</b>	<b>3.5t</b>	<b>3.5t</b>	<b>3.5t</b>	<b>4.5t</b>	<b>3.5t</b>	<b>4.5t</b>	
Min. kerb weight <sup>(1)</sup>	1,786	1,807	1,899	2,080	1,950	2,090	2,090	2,095	2,095	
Max. payload <sup>(2)</sup>	1,714	1,693	1,601	1,420	1,550	1,410	2,410	1,405	2,405	
Max. load on front axle	1,850									
Max. load on rear axle	2,100		2,300	2,620	2,300	2,620	3,200	2,620	3,200	
Max. towing weight	2,500/750		3,000/750		2,500/750		3,000/750			
Turning circle, kerb to kerb	13.6m	15.7m	13.6m						15.7m	
Turning circle, wall to wall	14.1m	16.2m	14.1m						16.2m	

### DIMENSIONS Chassis single cab (mm)

	Front-wheel drive			Rear-wheel drive				
	L2	L3	L2 SW	L2 TW	L3 SW	L2 Long overhang TW	L3 Long overhang TW	
Maximum body length	5,670	6,320	5,670	5,670	6,320	6,220	6,870	
Effective body length (min./max.)	3,184/3,466	3,834/4,840	3,184/4,295	3,184/4,276	3,834/4,926	3,734/4,275	4,384/5,470	
Side member sill height	735/740	736/741	771/774	784/787	771/775	784/787	786/789	
Width with extended door mirrors	2,654							
Max. effective body width (standard/extended repeaters)	2,170/2,350							
Ground clearance (min)	166							

(1) The kerb weight is the weight of the vehicle without the driver and with the fuel tank filled to 90%. This weight is given for the basic version and may vary according to the equipment and engine (by up to 330kg). (2) The payload is calculated as the difference between the Gross Vehicle Weight (GVW) and the kerb weight. SW: single wheels. TW: twin wheels.

## Chassis double cab

### FRONT-WHEEL DRIVE

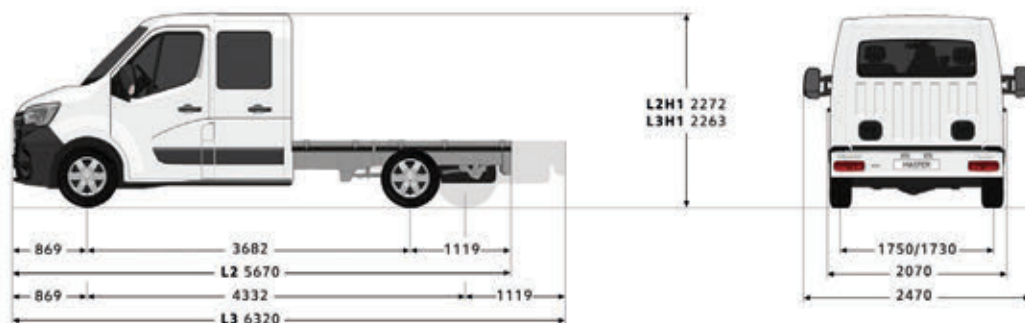

### REAR-WHEEL DRIVE

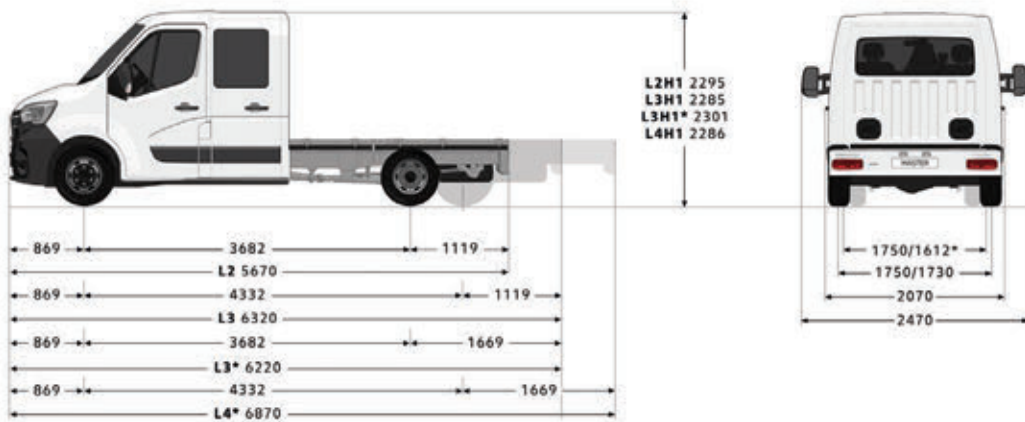

\* Twin wheels.

### WEIGHTS AND LOADS Chassis double cab (kg)

	Front-wheel drive		Rear-wheel drive	
	L2	L3	L3	L3 Long overhang
<b>GVW</b>	<b>3.5t</b>	<b>3.5t</b>	<b>3.5t TW</b>	<b>3.5t TW</b>
Min. kerb weight <sup>(1)</sup>	1,971	1,979	2,245	2,294
Max. payload <sup>(2)</sup>	1,529	1,521	1,255	1,206
Max. load on front axle	1,850			
Max. load on rear axle	2,100		2,620	2,620
Max. towing weight braked/unbraked	2,500/750		3,000/750	
Turning circle, kerb to kerb	13.6 m	15.7 m	13.6 m	15.7 m
Turning circle, wall to wall	14.1 m	16.2 m	14.1 m	16.2 m

### DIMENSIONS Chassis double cab (mm)

	Front-wheel drive			
	L2	L3	L3 TW	L3 Long overhang TW
Maximum body length	5,670	6,320	6,220	6,870
Effective body length (min./max.)	2,434/ 2,516	3,084/ 4,044	2,985/ 3,416	3,635/ 4,436
Side member sill height (min./max.)	727/732	731/736	775/780	778/781
Width with extended door mirrors	2,654			
Maximum effective body width (with standard/extended repeater)	2,170/2,350			
Ground clearance (min)	169		167	

(1) The kerb weight is the weight of the vehicle without the driver and with the fuel tank filled to 90%. This weight is given for the basic version and may vary according to the equipment and engine (by up to 330 kg). (2) The payload is calculated as the difference between the Gross Vehicle Weight (GVW) and the kerb weight. SW: single wheels, TW: twin wheels.



# Dimensions

## Platform cab

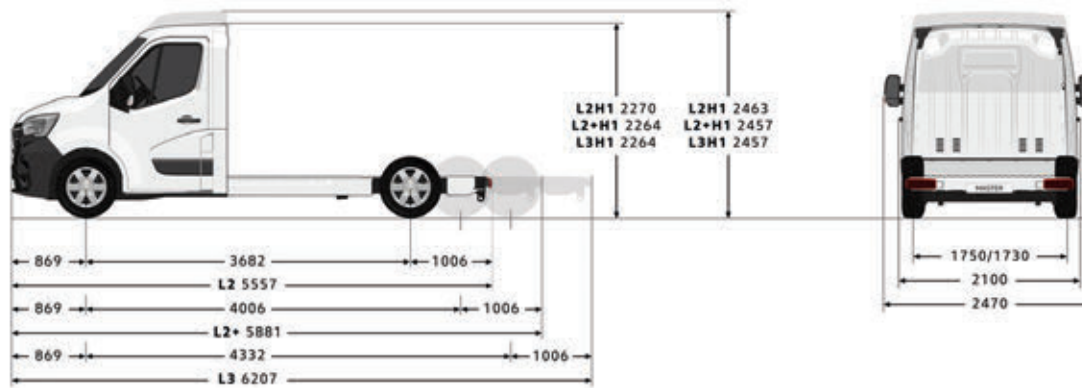

### WEIGHTS AND LOADS Platform cab (kg)

	Z.E. L2H1 Front-wheel drive	L2H1 Front-wheel drive	Z.E. L3H1 Front-wheel drive	L3H1 Front-wheel drive
<b>GVW</b>	3.1t	3.5 t	3.1t	3.5 t
Min. kerb weight <sup>(1)</sup>	1,773	1,717	1,795	1,725
Max. payload <sup>(2)</sup>	1,327	1,783	1,305	1,775
Max. load on front axle	1,700	1,850	1,700	1,850
Max. load on rear axle	1,900	2,100	1,900	2,100
Max. towing weight braked/unbraked	0/0	2,500/750	0/0	2,500/750
Turning circle, kerb to kerb	13.6m	13.6 m	15.7m	15.7 m
Turning circle, wall to wall	16.2m	14.1 m	16.2m	16.2 m

### DIMENSIONS Platform cab (mm)

	L2H1	L3H1
Maximum body length	5,557	6,207
Effective body length (min./max.)	3,091/3,313	
Maximum effective body width (with standard/extended repeater)	2,170/2,350	
Width with extended door mirrors	2,654	
Floor sill height (min./max.)	581/585	579/583
Ground clearance (min)	166	

(1) The kerb weight is the weight of the vehicle without the driver and with the fuel tank filled to 90%. This weight is given for the basic version and may vary according to the equipment and engine (by up to 330 kg). (2) The payload is calculated as the difference between the Gross Vehicle Weight (GVW) and the kerb weight.

## Luton Low Loader

### WEIGHTS AND LOADS Luton Low Loader (kg)

	L3H1 Front-wheel drive
<b>GVW</b>	3.5 t
Min. kerb weight <sup>(1)</sup>	2,262
Max. payload <sup>(2)</sup>	1,238
Max. load on front axle	1,850
Max. load on rear axle	2,100
Max. towing weight braked/unbraked	2,500/750

### DIMENSIONS Luton Low Loader (mm)

	L3H1
Maximum body length	6,700
Maximum effective body width (without door mirrors)	2,070
Width with door mirrors	2,470
Interior height	2,200
Overall height (unladen)	2,840
Cargo area length	4,150
Maximum loading area width	2,036

(1) The kerb weight is the weight of the vehicle without the driver and with the fuel tank filled to 90%. This weight is given for the basic version and may vary according to the equipment and engine (by up to 330 kg). (2) The payload is calculated as the difference between the Gross Vehicle Weight (GVW) and the kerb weight.



MASTER

# Options



**1. LED loadspace lighting** (at the rear and near the sliding side door) provide more white and intense light to optimise your working conditions.

**2. Reversing camera:** With information fed back onto the MediaNav multimedia system (when specified) or interior rear-view mirror (when MediaNav is not specified).

**3. Tablet holder:** The digital tablet holder is ideally placed above the radio on the dashboard. This system is suitable for a wide range of tablets of varying sizes. The holder can be used horizontally and vertically.

**4. MediaNav multimedia system:** Stay connected thanks to Renault MASTER's multimedia systems and Renault Easy Connect services. MediaNav Evolution has smartphone integration so you can use your favourite applications on the large touchscreen on the dashboard.

**5. Upgrade your passenger compartment:** The chrome air vents and the chrome gear knob provide a technical finish. The air conditioning with its electronic display allows the temperature to be adjusted to the nearest degree. Finally, the better quality Kompo upholstery will meet the expectations of the most demanding customers.





# Accessories

---



**1. Roof bars:** Very practical for transporting professional equipment and all other bulky loads. These roof bars meet all safety and quality standards and are available in either a set of 2 bar (maximum load: 89.5kg) or 4 bars (maximum load: 181.5kg).

**2. Rubber floor mats:** These waterproof and easy-to-maintain mats ensure total protection for the floor of your MASTER. They are quick to attach using 2 safety clips and come in packs of 2 or 4.

**3. Loading pack:** Essential for easy access to the roof. Pack includes the steel ladder, mounted inside the door for a better hold, and the aluminium roof rack, supplied with rear roller for easy loading.

**4. Kenwood Dashcam:** The Kenwood DVR-A501W dashcam is a great addition for added security and reassurance on the road. The on-board camera automatically starts recording as soon as the vehicle ignition is switched on. The dashcam is designed to give drivers peace of mind, as video footage is widely accepted and used for insurance claims. The pack includes a GPS integrated dashboard camera, touch panel control and parking mode recording.

**5. Rear parking sensors:** Makes parking easier by detecting any obstacles behind your vehicle and issuing an audible alert.

For more information, consult the MASTER accessories brochure. For prices, please refer to Renault Van Price Guide.

Accessories are fitted post-production, and may have an impact on real world fuel (actual) consumption and CO<sub>2</sub> figures.

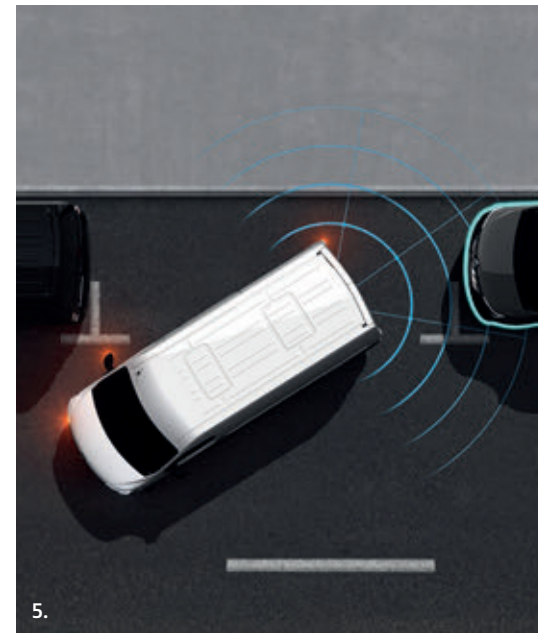



# Engines



## High-performance and more efficient engines

As part of application of the Euro 6d-temp emission standard, MASTER has modernised its range of engines. Benefits: a 100% Twin Turbo range, more power (up to +10 hp), more torque (up to +40 Nm) for new driving pleasure and better acceleration. All of this significantly reduces fuel consumption and CO<sub>2</sub> emissions. Example: the dCi 135 hp Twin Turbo gains 5 hp, +40 Nm whilst reducing its consumption by up to 15% in combined cycle (NEDC-BT)<sup>(1)</sup> enabling a net improvement in the total cost of ownership.

### How do I choose?

- On rear-wheel drive models the Euro VI Emission standard engine range meets your expectations with the dCi 130, ENERGY dCi 145.
- On Front Wheel Drive models (non converted versions), the ENERGY dCi 150 and 180 versions can be combined with a 6-speed automatic gearbox.
- Let's also remind you of the electric engine of MASTER Z.E., ideal for urban last mile delivery the last mile.

### "Twin Turbo" technology

It enables a diesel engine to combine torque at low speeds and high power with immediate benefit to driving pleasure. It incorporates two standard-mounted turbochargers:

- the first turbo provides high torque from low speeds to give you greater responsiveness when pulling away and restarting;
- the second turbo takes over at higher speeds, letting you use more power without running out of steam for smooth, steady, linear acceleration.

### Euro 6/VI and AdBlue®

The new range has the SCR (catalytic reduction system) enabling all of our engines to significantly reduce NO<sub>x</sub> emissions by injecting a liquid called AdBlue®. AdBlue® is a liquid, non-toxic, non-flammable and water-based solution, which is injected at the start of the exhaust system not line. This significantly reduces pollutant emissions while preserving the performance of our engines. The AdBlue® tank is located under the body at the front and is filled via a flap which is located on the right side of the vehicle (can be filled from a bottle, or HGV AdBlue® pump in service stations).

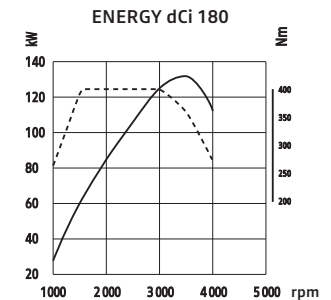
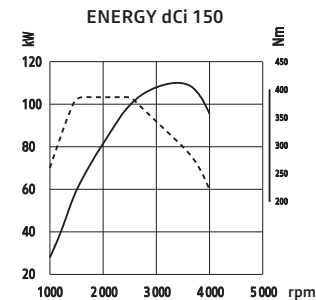
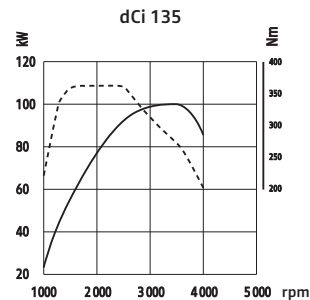

--- Torque (Nm)    — Power (hp)

# Technical specification

	Euro 6d-Temp						
	dCi 135 BVM6 N1	ENERGY dCi 150 BVM6/BVR6* N1	ENERGY dCi 180 BVM6/BVR6* N1				
Power (hp/kW)	135/100	150/110	180/132				
Stop & Start	No	Yes	Yes				
Engine speed at max. power (rpm)	3,500	3,500	3,500				
Torque (N.m)	360	385	400				
Engine speed at max. torque (rpm)	1,500	1,500	1,500				
Top speed (mph)	94	97	103				
0-62 mph (s)	13.5	12.1	11.3				
Type of bodywork	FWD vans and crew vans, non-converted	Converted chassis cabs, tippers, dropside, platform cabs and FWD panel vans	FWD vans, non-converted	Converted chassis cabs, tippers, dropside, platform cabs and FWD panel vans	FWD vans, non-converted		
			BVM6	BVR6*	BVM6	BVR6*	
			WLTP <sup>(1)</sup>				
Combined fuel consumption (mpg)	32.5-29.1	22.8	31.0-29.4	31.4-28.5	23.0	29.4	29.4
CO <sub>2</sub> emissions (g/km) (combined cycle)	230-255	327	240-252	235-260	323	252	252

(1) WLTP figures shown are for comparability purposes; only compare figures with vehicles tested to the same technical procedures. Actual real world driving results may vary depending on factors such as weather conditions, driving styles, vehicle load or any accessories fitted after registration. WLTP is a new test used for fuel consumption and CO<sub>2</sub> figures. Please visit [renault.co.uk/configure](http://renault.co.uk/configure) for WLTP figures for any selected options.

\*BVR6 automatic gearbox engine data.

	ENERGY dCi 145	dCi 130	ENERGY dCi 145
	All FWD Vans and Conversions	All RWD Vans and Conversions	All RWD Vans and Conversions
Type of bodywork			
Certification category	N1	N1	N1
Wheels	SW	TW	TW
Power (hp/kW)	145/107	130/96	145/107
Stop & Start	Yes	No	Yes
Engine speed at max. power (rpm)	3,500	3,500	3,500
Torque (N.m)	360	330	360
Engine speed at max. torque (rpm)	1,500	1,500	1,500
Top speed (mph)	95	92	93
		WLTP <sup>(1)</sup>	
Combined cycle consumption (mpg)	22.8 - TBC	TBC	32.8 - TBC
CO <sub>2</sub> emissions (g/km) (combined cycle)	327 - TBC	TBC	224 - TBC

(1) WLTP figures shown are for comparability purposes; only compare figures with vehicles tested to the same technical procedures. Actual real world driving results may vary depending on factors such as weather conditions, driving styles, vehicle load or any accessories fitted after registration. WLTP is a new test used for fuel consumption and CO<sub>2</sub> figures. Please visit [renault.co.uk/configure](http://renault.co.uk/configure) for WLTP figures for any selected options.

# MASTER van

## MASTER VAN - PANEL VAN

VERSIONS	WLTP CO <sub>2</sub> (g/km)*	Combined fuel consumption (mpg)*	Load volume (m <sup>3</sup> )	Max. payload (kg)
<b>BUSINESS</b>				
<b>L1H1</b>				
FWD SL28 dCi 135 Business MY19	230	32.5	8.0	873
FWD SL28 ENERGY dCi 150 Quickshift6 Business MY19	235	31.4	8.0	873
<b>L1H2</b>				
FWD SM35 dCi 135 Business MY19	244	30.4	9.0	1551
FWD SM35 ENERGY dCi 150 Quickshift6 Business MY19	249	29.7	9.0	1551
<b>L2H2</b>				
FWD MM33 dCi 135 Business MY19	243	30.7	10.8	1279
FWD MM33 ENERGY dCi 150 Business MY19	240	31.0	10.8	1279
FWD MM35 dCi 135 Business MY19	245	30.4	10.8	1479
FWD MM35 ENERGY dCi 150 Business MY19	242	31.0	10.8	1479
FWD MM35 ENERGY dCi 150 Quickshift6 Business MY19	250	29.7	10.8	1479
<b>L2H3</b>				
FWD MH35 dCi 135 Business MY19	253	29.4	12.3	1454
FWD MH35 ENERGY dCi 150 Business MY19	250	29.7	12.3	1454
<b>L2H2 LONG OVERHANG</b>				
RWD MML35 dCi 130 Business MY19	224 <sup>(1)</sup>	32.8 <sup>(1)</sup>	12.4	1157
RWD MML35TW ENERGY dCi 145 Business MY19	225 <sup>(1)</sup>	32.8 <sup>(1)</sup>	12.4	1101
<b>L3H2</b>				
FWD LM35 dCi 135 Business MY19	247	30.1	13.0	1384
FWD LM35 ENERGY dCi 150 Business MY19	244	30.4	13.0	1384
FWD LM35 ENERGY dCi 150 Quickshift6 Business MY19	252	29.4	13.0	1384
FWD LM35 ENERGY dCi 180 Business MY19	252	29.4	13.0	1384
FWD LM35 ENERGY dCi 180 Quickshift6 Business MY19	252	29.4	13.0	1384
<b>L3H3</b>				
FWD LH35 dCi 135 Business MY19	255	29.1	14.8	1377
FWD LH35 ENERGY dCi 150 Business MY19	252	29.4	14.8	1377
FWD LH35 ENERGY dCi 150 Quickshift6 Business MY19	260	28.5	14.8	1377
<b>L3H2 LONG OVERHANG</b>				
RWD LML35 dCi 130 Business MY19	224 <sup>(1)</sup>	32.8 <sup>(1)</sup>	14.9	1157
RWD LML35 ENERGY dCi 145 Business MY19	211 <sup>(1)</sup>	34.9 <sup>(1)</sup>	14.9	1157
RWD LML35TW ENERGY dCi 145 Business MY19	TBC	TBC	14.9	1061
RWD LML45TW ENERGY dCi 145 Business MY19	TBC	TBC	14.9	2061
<b>L3H3 LONG OVERHANG</b>				
RWD LHL35 dCi 130 Business MY19	224 <sup>(1)</sup>	32.8 <sup>(1)</sup>	17.0	1110
RWD LHL35 ENERGY dCi 145 Business MY19	TBC	TBC	17.0	1110
RWD LHL35TW ENERGY dCi 145 Business MY19	TBC	TBC	17.0	990
RWD LHL45TW ENERGY dCi 145 Business MY19	224 <sup>(1)</sup>	32.8 <sup>(1)</sup>	17.0	1990
<b>BUSINESS+</b>				
<b>L1H1</b>				
FWD SL28 dCi 135 Business+ MY19	230	32.1	8.0	848
<b>L2H2</b>				
FWD MM33 dCi 135 Business+ MY19	244	30.4	10.8	1254
FWD MM35 dCi 135 Business+ MY19	246	30.1	10.8	1454
FWD MM35 ENERGY dCi 150 Business+ MY19	243	30.4	10.8	1454
FWD MM35 ENERGY dCi 150 Quickshift6 Business+ MY19	251	29.4	10.8	1454
<b>L3H2</b>				
FWD LM35 dCi 135 Business+ MY19	249	29.7	13.0	1359
FWD LM35 ENERGY dCi 150 Business+ MY19	246	30.4	13.0	1359
FWD LM35 ENERGY dCi 150 Quickshift6 Business+ MY19	254	29.1	13.0	1359



## MASTER CREW VAN - 7 SEATS

VERSIONS	WLTP CO <sub>2</sub> (g/km) <sup>†</sup>	Combined fuel consumption (mpg) <sup>†</sup>	Load volume (m <sup>3</sup> )	Max. payload (kg)
<b>BUSINESS</b>				
<b>L2H2</b>				
FWD MM35 dCi 135 Business Crew Van MY19	249	29.7	6.9	1274
<b>L3H2</b>				
FWD LM35 dCi 135 Business Crew Van MY19	252	29.4	9.0	1180
<b>BUSINESS+</b>				
<b>L2H2</b>				
FWD MM35 dCi 135 Business+ Crew Van MY19	250	29.7	6.9	1249
<b>L3H2</b>				
FWD LM35 dCi 135 Business+ Crew Van MY19	253	29.4	9.0	1155

## MASTER Z.E. PANEL VAN - BUSINESS - BATTERY FULL PURCHASE

VERSIONS	WLTP CO <sub>2</sub> (g/km) <sup>†</sup>	Power unit output kW (bhp)	Load volume (m <sup>3</sup> )	Max. payload (kg)
<b>L1H1</b>				
FWD SL31 i Z.E. Business MY19	0	57 (76)	8.0	1078
<b>L1H2</b>				
FWD SM31 i Z.E. Business MY19	0	57 (76)	9.0	1050
FWD SM35 i Z.E. Business MY20	0	57 (76)	9.0	1425
<b>L2H3</b>				
FWD MM31 i Z.E. Business MY19	0	57 (76)	10.8	1006
FWD MM35 i Z.E. Business MY20	0	57 (76)	10.8	1381
<b>L3H2</b>				
FWD LM31 i Z.E. Business MY19	0	57 (76)	13.0	925
FWD LM35 i Z.E. Business MY20	0	57 (76)	13.0	1300

<sup>†</sup> WLTP figures shown are for comparability purposes; only compare figures with vehicles tested to the same technical procedures. Actual real world driving results may vary depending on factors such as weather conditions, driving styles, vehicle load or any accessories fitted after registration. WLTP is a new test used for fuel consumption and CO<sub>2</sub> figures. Please visit [renault.co.uk/configure](https://www.renault.co.uk/configure) for WLTP figures for any selected options. (1) Heavy Duty engine homologated and tested to NEDC protocol.

# MASTER options

	Panel	Business Panel Z.E.	FWD Crew	Business+ Panel	Crew	RWD Business Panel
<b>BASICS</b>						
Airbag - front passenger	○	-	○	○	○	○
Airbag - front passenger, front lateral curtain (driver and passenger) and single passenger seat (height adjustable) with lumbar adjustment (standard on LWB) <sup>(5)</sup>	○	-	-	○	-	○
Air suspension <sup>(6)(18)</sup>	○	-	○	○	○	-
Battery interface	○	○	○	○	○	○
CAN interface unit	○	-	○	○	○	○
Digital tachograph and CAN interface unit <sup>(7)</sup>	○	-	○	○	○	○
Engine speed limiter (56mph/90kmh OR 62mph/100kmh OR 68mph/110kmh OR 81mph/130kmh) <sup>(8)</sup>	○	-	○	○	○	○
Fuel tank - 105 litres	○	-	○	○	○	○
Key - additional (third) key	○	○	○	○	○	○
Key - 2 button hands free key	○	○	○	○	○	○
Key - 3 button key	○	○	○	●	●	○
Locking differential	-	-	-	-	-	○
Mudflaps (front and rear)	○	○	○	○	○	○
Power take off - engine <sup>(1)(9)</sup>	○	-	○	-	-	○
Power take off - gearbox <sup>(10)</sup>	-	-	-	-	-	○
Rear step	○	○	○	○	○	●
Reinforced Battery <sup>(11)</sup>	○	●	○	○	○	○
Smoker pack	○	○	○	○	○	○
<b>CONNECTIVITY</b>						
12V power point in load area	○	○	○	●	●	○
MediaNav multimedia system: 7" touchscreen, Navteq navigation, FM/AM/DAB tuner, 2x20W speakers, Bluetooth® hands-free calls, USB and AUX sockets <sup>(2)</sup>	○	-	○	○	○	○
<b>COMFORT</b>						
Cruise control with speed limiter	○	○	○	○	○	○
Driver's seat - fully adjustable suspension type <sup>(13)(24)</sup>	○	○	○	●	○	○
Electric front windows (driver's side 'one touch' descending)	○	○	○	●	●	○
Kompo upholstery	○	○	○	-	-	-
Manual air conditioning with pollen filter	○	○	○	●	●	○
Passenger's seat - height-adjustable single seat with armrest	○	○	○	○	○	○
Passenger's seat - height-adjustable with lumbar adjustment single seat <sup>(21)</sup>	○	○	○	○	○	○
Pivoting seatback table <sup>(13)(22)</sup>	○	○	●	○	○	○
Pivoting seatback table with dual split underseat storage compartment <sup>(13)(22)</sup>	○	○	○	●	●	○
Driving pack: cruise control with speed limiter, air conditioning with pollen filter, one-touch electric front windows	○	-	○	-	-	○
<b>PROTECT</b>						
Advanced emergency braking system <sup>(23)</sup>	○	-	○	○	○	○
2 Additional anchorage points in loading area, weight allowed per anchorage point: approximately 500kg	○	○	○	○	○	○
Blind spot warning <sup>(20)(26)</sup>	○	-	○	-	-	○
Bulkhead - full steel with glazing	○	-	-	○	-	○
Increased idle speed <sup>(14)</sup>	○	-	○	○	○	○
LED loadspace lighting	○	○	○	○	○	○
Rear parking camera with rear parking sensors	○	○	○	○	○	○
Front parking sensors (Inc. rear sensors)	○	○	○	○	○	○
Front parking sensors (Inc. rear sensors) with rear parking camera	○	○	○	○	○	○
<b>Parking pack 1:</b> front & rear parking sensors plus cruise control & wide view mirror	○	-	○	-	-	○ <sup>(8)</sup>
<b>Parking pack 2:</b> front & rear parking sensors, rear parking camera plus cruise control & wide view mirror	○	-	○	-	-	○ <sup>(8)</sup>
<b>Parking pack 3:</b> front & rear parking sensors plus cruise control, wide view mirror & blind spot warning	○	-	○	-	-	○ <sup>(8)</sup>
<b>Parking pack 4:</b> front & rear parking sensors, rear parking camera plus cruise control, wide view mirror & blind spot warning	○	-	○	-	-	○ <sup>(8)</sup>
Rear parking sensors	○	○	○	●	●	○
Resin coated plywood floor	○	○	○	○	○	○
Rear View Assist Camera (Does not function when vehicle is reversing)	○	-	○	○	○	○
Ply lining - full height ply lined side panels and floor - ply lined with resin coating <sup>(3)</sup>	○	-	○	○	○	○
Ply lining - half height ply lined side panels <sup>(6)</sup>	○	○	○	○	○	○

	Panel	Business Panel Z.E.	FWD Crew	Business+ Panel	Crew	RWD Business Panel
Towing capacity - Twin wheel heavy duty option : Increase to 3,500 kg <sup>(8) (17)</sup>	-	-	-	-	-	○
Tyre pressure monitoring system	○	○	○	○	○	-
Wide view mirror	○	○	○	●	●	○
4x4 <sup>(4)</sup>	-	-	-	-	-	○
Lane departure warning system & Automatic headlight high/ low beam <sup>(25) (26)</sup>	○	-	○	○	○	○
<b>STYLE</b>						
16" alloy wheels <sup>(19)</sup>	○	-	○	○	○	-
16" steel wheels with large wheel stylers <sup>(15)</sup>	○	○	○	●	●	○
All-weather tyres <sup>(6) (16)</sup>	○	-	○	○	○	○
Metallic paint	○	○	○	○	○	○
Tow bar	○	-	○	○	○	○
Front fog lights	○	-	○	○	○	-
<b>ELECTRIC</b>						
EVSE Cable for 10 amp charging using domestic 3-pin plug	-	○	-	-	-	-
My Z.E. Connect - 3 year renewal subscription (one year free subscription) <sup>(13)</sup>	-	○	-	-	-	-

● = Standard (therefore no cost) ○ = Optional - = Not available

(1) RWD and FWD 135, 150 and 170 versions must be taken with Manual air conditioning. Not available on Quickshift engines. (2) For list of compatible Bluetooth devices visit <https://www.renault.co.uk/services/multimedia/bluetooth-compatibility.html> (3) Not available with Glazing Pack or with LML and LHL versions if not twin wheel variant (4) Must be ordered with a locking differential and is not available with Power take off, MediaNav, Lane departure warning, Automatic high-low beam or 4.5T versions. Due to the weight of the 4x4 system selecting this option will reduce your payload. (5) Front lateral airbag covers thorax only (6) Not available on SWB versions (7) Standard on 4.5T and needs to be calibrated by the dealership on hand-over (8) Not available on 4.5T versions (9) Must be taken with battery interface (10) Not available with increase idle speed. Not available on Quickshift (11) Not available on ENERGY or Quickshift engines (12) Cannot be taken with Airbag - front passenger (13) Not available with front lateral curtain airbag (14) Not available with Power take off - gearbox (15) Not available on twin RWD versions (16) Not compatible with Alloy wheels (17) Only available on Twin RWD versions (18) Requires Battery interface and Can interface unit (19) Not available with All-weather tyres (20) Must be ordered with Rear parking sensors (21) Standard on LWB Crew Van Versions (22) Not available on LWB Crew Van Versions: single passenger seat is standard (23) Cannot be ordered with Front parking sensors (24) Not available on 3.1T Z.E. versions (25) Must be ordered with Blind spot warning on Quickshift engines (26) Must be ordered with MediaNav on Quickshift engines

# Doors, windows and bulkheads

	PANEL	CREW
<b>DOORS, WINDOWS &amp; BULKHEADS</b>		
Right side loading door - unglazed	○	-
Glazing for side loading doors / right hand panel - non-opening windows <sup>(4)</sup>	○	●
Opening windows in glazed side loading doors <sup>(1)</sup>	○	○
Rear doors - glazed, 180°	○	○
Rear doors - glazed 270° <sup>(2) (3)</sup>	○	-
Rear doors - unglazed, 270° <sup>(2)</sup>	○	○
Heated rear window	○	○
Glazing pack - Left side loading door - glazed with non opening window, Right side panel - glazed with non opening window, Rear doors - glazed, 180°, Left and right quarter panels - glazed	○	-

● = Standard (therefore no cost) ○ = Optional - = Not available

No window or door options available on MASTER Z.E.

(1) Must be taken with glazed sides (2) Not available on SWB versions (3) Not compatible with door ladder (4) Not compatible with Driver's seat - fully adjustable suspension type



# MASTER Conversions

## MASTER CONVERSIONS

VERSIONS	WLTP CO <sub>2</sub> (g/km)*	Combined fuel consumption (mpg)*	Max. payload (kg)
<b>CHASSIS CAB SINGLE CAB</b>			
<b>L2H1</b>			
Chassis Cab FWD ML35 dCi 135 Business MY19	327	22.8	1714
Chassis Cab RWD ML35 dCi 130 Business MY19	TBC	TBC	1601
<b>L2H1 LONG OVERHANG</b>			
Chassis Cab RWD MLL45TW ENERGY dCi 145 Business MY19	TBC	TBC	2410
<b>L3H1</b>			
Chassis Cab FWD LL35 dCi 135 Business MY19	327	22.8	1693
Chassis Cab FWD LL35 ENERGY dCi 150 Business MY19	323	23.0	TBC
Chassis Cab RWD LL35 dCi 130 Business MY19	TBC	TBC	1550
<b>L3H1 LONG OVERHANG</b>			
Chassis Cab RWD LLL35TW ENERGY dCi 145 Business MY19	TBC	TBC	1405
<b>CHASSIS CAB DOUBLE CAB</b>			
<b>L3H1</b>			
Chassis Double Cab FWD LL35 ENERGY dCi 150 Business MY19	323	23.0	1521
<b>L3H1 LONG OVERHANG</b>			
Chassis Double Cab RWD LLL35TW ENERGY dCi 145 Business MY19	TBC	TBC	1206
<b>PLATFORM CAB</b>			
<b>L3H1</b>			
Platform Cab FWD LL35 dCi 135 Business MY19	327	22.8	1775
Platform Cab FWD LL35 dCi 145 Business MY20	327	22.8	1775
Platform Cab FWD LL35 ENERGY dCi 150 Business MY19	323	23.0	1775
Platform Cab FWD LL35 dCi 150 Quickshift6 Business MY19	326	22.8	1775
<b>DROPSIDE SINGLE CAB</b>			
<b>L2H1 (REAR CORNER PILLARS)</b>			
Chassis Cab Dropside (incl. Rear Corner Pillars) FWD ML35 dCi 135 Business MY20	327	22.8	1471
<b>L3H1 (REAR CORNER PILLARS)</b>			
Chassis Cab Dropside (incl. Rear Corner Pillars) FWD LL35 dCi 135 Business MY20	327	22.8	1447
Chassis Cab Dropside (incl. Rear Corner Pillars) FWD LL35 ENERGY dCi 150 Business MY20	323	23.0	1447
Chassis Cab Dropside (incl. Rear Corner Pillars) RWD LL35 dCi 130 Business MY20	TBC	TBC	1590
<b>L3H1 LONG OVERHANG (REAR CORNER PILLARS)</b>			
Chassis Cab Dropside (incl. Rear Corner Pillars) RWD LLL35TW ENERGY dCi 145 Business MY20	TBC	TBC	1635
<b>L2H1 (TAIL LIFT)</b>			
Chassis Cab Dropside (incl. Tail Lift) FWD ML35 dCi 135 Business MY20	327	22.8	1306
<b>L3H1 (TAIL LIFT)</b>			
Chassis Cab Dropside (incl. Tail Lift) FWD LL35 dCi 135 Business MY20	327	22.8	1282
Chassis Cab Dropside (incl. Tail Lift) FWD LL35 ENERGY dCi 150 Business MY20	323	23.0	1282
Chassis Cab Dropside (incl. Tail Lift) RWD LL35 dCi 130 Business MY20	TBC	TBC	1425
<b>L3H1 LONG OVERHANG (TAIL LIFT)</b>			
Chassis Cab Dropside (incl. Tail Lift) RWD LLL35TW ENERGY dCi 145 Business MY20	TBC	TBC	1470
<b>DROPSIDE DOUBLE CAB</b>			
<b>L3H1 (REAR CORNER PILLARS)</b>			
Chassis Double Cab Dropside (incl. Rear Corner Pillars) FWD LL35 ENERGY dCi 150 Business MY20	TBC	42.8	1664
<b>L3H1 (TAIL LIFT)</b>			
Chassis Double Cab Dropside (incl. Tail Lift) FWD LL35 ENERGY dCi 150 Business MY20	TBC	42.8	1499

## MASTER CONVERSIONS

VERSIONS	WLTP CO <sub>2</sub> (g/km) <sup>†</sup>	Combined fuel consumption (mpg) <sup>†</sup>	Max. payload (kg)
<b>TIPPER SINGLE CAB</b>			
<b>L2H1</b>			
Tipper Single Cab FWD ML35 dCi 135 Business MY19	327	22.8	1217
Tipper Single Cab RWD ML35 dCi 130 Business MY19	TBC	TBC	1104
Tipper Single Cab RWD ML35TW dCi 130 Business MY19	TBC	TBC	934
<b>TIPPER DOUBLE CAB</b>			
<b>L3H1</b>			
Tipper Double Cab RWD LL35 ENERGY dCi 145 Business MY19	TBC	TBC	890
<b>L2H1 LONG OVERHANG</b>			
Tipper Double Cab RWD MLL35TW dCi 130 Business MY19	TBC	TBC	825
<b>ALUMINIUM TIPPER SINGLE CAB</b>			
<b>L2H1</b>			
Aluminium Tipper Single Cab FWD ML35 dCi 135 Business MY19	327	22.8	1314
Aluminium Tipper Single Cab RWD ML35 dCi 130 Business MY19	TBC	TBC	1201
Aluminium Tipper Single Cab RWD ML35TW dCi 130 Business MY19	TBC	TBC	1020
<b>ALUMINIUM TIPPER DOUBLE CAB</b>			
<b>L3H1</b>			
Aluminium Tipper Double Cab RWD LL35 dCi 130 Business MY19	TBC	TBC	953
Aluminium Tipper Double Cab RWD LL35TW ENERGY dCi 145 Business MY19	TBC	TBC	808
<b>LUTON LOW LOADER</b>			
<b>L3H1</b>			
Luton Low Loader FWD LL35 dCi 135 Business MY19	327	22.8	1238
Luton Low Loader FWD LL35 ENERGY dCi 150 Business MY19	323	23.0	1238
Luton Low Loader FWD LL35 dCi 150 Quickshift6 Business MY19	326	22.8	1238
<b>LUTON BOX VAN</b>			
<b>L3H1</b>			
Luton Box Van 20M <sup>3</sup> RWD LL35 dCi 130 Business MY19	TBC	TBC	1061
Luton Box Van 20M <sup>3</sup> FWD LL35 ENERGY dCi 145 Business MY19	TBC	TBC	1204
Luton Box Van 20M3 (incl. Tail Lift) FWD LL35 ENERGY dCi 145 Business MY20	TBC	TBC	1204
Luton Box Van 20M3 (incl. Tail Lift) RWD LL35 dCi 130 Business MY20	TBC	TBC	1061

## MASTER Z.E. PLATFORM CAB - BUSINESS - BATTERY FULL PURCHASE

VERSIONS	WLTP CO <sub>2</sub> (g/km) <sup>†</sup>	Power Unit Output kW (bhp)	Max. payload (kg)
<b>L3H1 PLATFORM CAB</b>			
Platform Cab FWD LL31 i Z.E. Business MY19	0	57 (76)	1305
Platform Cab FWD LL35 i Z.E. Business MY20	0	57 (76)	1720
<b>L3H1 LUTON LOW LOADER</b>			
Luton Low Loader FWD LL31 i Z.E. Business MY20	0	57 (76)	768
Luton Low Loader FWD LL35 i Z.E. Business MY20	0	57 (76)	1183
<b>L2H1 CHASSIS CAB</b>			
Chassis Cab FWD ML35 i Z.E. Business MY20	0	57 (76)	1620
<b>L3H1 CHASSIS CAB</b>			
Chassis Cab FWD LL35 i Z.E. Business MY20	0	57 (76)	1600

<sup>†</sup> WLTP figures shown are for comparability purposes; only compare figures with vehicles tested to the same technical procedures. Actual real world driving results may vary depending on factors such as weather conditions, driving styles, vehicle load or any accessories fitted after registration. WLTP is a new test used for fuel consumption and CO<sub>2</sub> figures. Please visit [renault.co.uk/configure](http://renault.co.uk/configure) for WLTP figures for any selected options. (1) Heavy Duty engine homologated and tested to NEDC protocol.

# MASTER Conversions options

	CHASSIS					PLATFORM		DROPSIDE				TIPPER			LUTON LOW LOADER		LUTON BOX VAN		
	SINGLE CAB			DOUBLE CAB		SINGLE CAB		SINGLE CAB		DOUBLE CAB		SINGLE CAB		DOUBLE CAB	FWD	Z.E.	FWD	RWD	
	FWD	RWD	Z.E.	FWD	RWD	FWD	Z.E.	FWD	RWD	FWD	RWD	FWD	RWD						
<b>BASICS</b>																			
Air suspension <sup>(16)(20)</sup>	○	-	-	○	-	○	-	○	-	○	-	○	-	○	-	○	-	○	-
B-pillar wiring connection point <sup>(6)</sup>	○	○	○	-	-	○	○	○	○	-	-	○	○	-	●	○	-	-	
Battery interface	○	○	-	○	○	○	-	●	●	●	●	●	●	○	-	○	○	○	
CAN interface unit	○	○	-	○	○	○	-	○	○	○	○	○	○	○	-	○	○	○	
Digital tachograph and CAN interface unit <sup>(5)</sup>	○	○	-	○	○	○	-	○	○	○	○	○	○	○	-	○	○	○	
Engine speed limiter - 56mph/90kmh (to meet legal requirement) <sup>(5)</sup>	○	○	-	○	○	○	-	○	○	○	○	○	○	○	-	○	○	○	
Engine speed limiter (56mph/90kmh or 62mph/100kmh or 68mph/110kmh) <sup>(6)</sup>	○	○	-	○	○	○	-	○	○	○	○	○	○	○	-	○	○	○	
Fuel tank - 105 litres <sup>(7)</sup>	○	○	-	○	○	○	-	○	○	○	○	○	○	○	-	○	○	○	
Increased idle speed <sup>(8)</sup>	○	○	-	○	○	○	-	○	○	○	○	○	○	○	-	○	○	○	
Key - 2 button hands free key	○	○	○	○	○	○	○	○	○	○	○	○	○	○	○	○	○	○	
Key - additional (third) key	○	○	○	○	○	○	○	○	○	○	○	○	○	○	○	○	○	○	
Locking differential <sup>(17)</sup>	-	○	-	-	○	-	-	-	○	-	○	-	○	-	-	-	-	○	
Long wiring loom	○	○	-	○	○	○	-	-	-	-	-	○	○	○	-	-	-	-	
Power take off - engine	-	-	-	-	-	-	-	-	-	○	-	-	○	-	-	-	-	-	
Power take off - engine, and manual air conditioning with pollen filter <sup>(8)(9)</sup>	-	○	-	-	○	-	-	○	○	-	○	○	○	○	-	-	-	○	
Power take off - engine, battery interface and air conditioning with pollen filter <sup>(8)(9)</sup>	○	-	-	○	-	○	-	-	-	-	-	-	-	○	-	○	-	-	
Power take off - engine and converter pack 1 <sup>(3)(8)(9)(18)(19)</sup>	○	○	-	-	-	○	-	-	-	-	-	-	-	-	-	-	-	-	
Power take off - engine and converter pack 2 <sup>(3)(8)(9)(18)</sup>	○	○	-	○	○	○	-	-	-	-	-	-	-	○	-	-	-	-	
Power take off - gearbox <sup>(8)(9)(11)(17)</sup>	-	○	-	-	○	-	-	○	-	○	-	○	○	-	-	-	-	○	
Reinforced battery <sup>(9)(12)(23)</sup>	○	○	●	○	○	○	●	○	○	○	○	○	○	○	●	○	○	○	
Smoker pack	○	○	○	○	○	○	○	○	○	○	○	○	○	○	○	○	○	○	
Towing twin wheel heavy duty option: increase to 3,500 Kg <sup>(6)(9)(10)</sup>	-	○	-	-	○	-	-	-	○	-	○	-	○	-	-	-	-	○	
<b>Converter pack 1:</b> Battery interface, B pillar wiring connection point, long wiring loom	○	○	-	-	-	○ <sup>(23)</sup>	-	-	-	-	-	-	-	○ <sup>(23)</sup>	-	○	-	-	
<b>Converter pack 2:</b> CAN interface unit, battery interface, long wiring loom	○	○	-	○	○	○	-	-	-	-	-	-	-	○	-	○	-	-	
<b>Converter pack 3:</b> CAN interface unit, battery interface, B pillar wiring connection point, long wiring loom	○	○	-	-	-	○ <sup>(23)</sup>	-	-	-	-	-	-	-	○ <sup>(23)</sup>	-	○	-	-	
<b>CONNECTIVITY</b>																			
MediaNav multimedia system: 7" touchscreen, Navteq navigation, FM/AM/DAB tuner, 2x20W speakers, Bluetooth® hands-free calls, USB and AUX sockets <sup>(2)</sup>	○	○	-	○	○	○	-	○	○	○	○	○	○	○	-	○	○	○	
<b>COMFORT</b>																			
Cruise control with speed limiter	○	○	○	○	○	○	○	○	○	○	○	○	○	○	○	○	○	○	
Driver's seat - fully adjustable suspension type <sup>(13)(24)</sup>	○	○	○	○	○	○	○	○	○	○	○	○	○	○	○	○	○	○	
Electric front windows - driver's side one-touch descending	○	○	○	○	○	○	○	○	○	○	○	○	○	○	○	○	○	○	
Manual air conditioning with pollen filter	○	○	-	○	○	○	-	○	○	○	○	○	○	○	-	○	○	○	
Passenger's seat - height-adjustable with lumbar adjustment single seat	○	○	○	○	○	○	○	○	○	○	○	○	○	○	○	○	○	○	
Passenger's seat - height-adjustable single seat <sup>(14)</sup>	○	○	○	○	○	○	○	○	○	○	○	○	○	○	○	○	○	○	
Pivoting seatback table <sup>(15)</sup>	○	○	○	○	○	○	○	○	○	○	○	○	○	○	○	○	○	○	
Pivoting seatback table with dual split underseat storage compartment <sup>(15)</sup>	○	○	○	○	○	○	○	○	○	○	○	○	○	-	○	○	○	○	
<b>Driving Pack:</b> Manual air conditioning with pollen filter, Electric front windows - driver's side one-touch descending, cruise control with speed limiter	○	○	-	○	○	○	-	○	○	○	○	○	○	○	-	○	○	○	



	CHASSIS					PLATFORM		DROPSIDE				TIPPER			LUTON LOW LOADER		LUTON BOX VAN	
	SINGLE CAB			DOUBLE CAB		SINGLE CAB		SINGLE CAB		DOUBLE CAB		SINGLE CAB	DOUBLE CAB		SINGLE CAB	Z.E.	FWD	RWD
	FWD	RWD	Z.E.	FWD	RWD	FWD	Z.E.	FWD	RWD	FWD	RWD	FWD	RWD	RWD	FWD	Z.E.	FWD	RWD
<b>PROTECT</b>																		
Advanced emergency braking system <sup>(25)</sup>	o	o	-	o	o	o	-	o	o	o	o	o	o	o	o	-	o	o
Airbag - front passenger	o	o	o	o	o	o	o	o	o	o	o	o	o	o	o	o	o	o
Airbag - front passenger and front lateral curtain (driver and passenger), and single passenger seat (height adjustable) with lumbar adjustment	o	o	o	o	o	o	o	o	o	o	o	o	o	o	o	o	o	o
Automatic high/low beam and front fog lights (4.5T versions only)	-	o	-	-	-	-	-	-	-	-	-	-	-	-	-	-	-	-
Front fog lights	o	o	o	o	o	o	o	o	o	o	o	o	o	o	o	o	o	o
Wide view mirror	o	o	o	o	o	o	o	o	o	o	o	o	o	o	o	o	o	o
4x4 <sup>(4)</sup>	-	o	-	-	-	-	-	-	o	-	-	-	o	-	-	-	-	-
<b>STYLE</b>																		
16" alloy wheels <sup>(16)(24)</sup>	o	-	-	o	-	o	-	o	-	o	-	o	-	-	o	-	o	-
16" steel wheels with large wheel stylers <sup>(12)</sup>	o	o	o	o	o	o	o	o	o	o	o	o	o	o	o	o	o	o
All-weather tyres <sup>(16)</sup>	o	o	-	o	o	o	-	o	o	o	o	o	o	o	o	-	o	o
Dropside - tool compartment and ladder rack <sup>(21)(22)</sup>	-	-	-	-	-	-	-	o	o	o	o	-	-	-	-	-	-	-
Extended door mirror arms	o	o	o	o	o	o	o	o	o	o	o	o	o	o	o	o	o	o
Metallic paint <sup>(1)</sup>	o	o	o	o	o	o	o	o	o	o	o	o	o	o	o	o	o	o
Mudflaps (front and rear)	o	o	o	o	o	o	o	o	o	o	o	o	o	o	o	o	o	o
Tow bar <sup>(7)</sup>	o	o	-	o	o	o	-	o	o	o	o	o	o	o	o	-	o	-
<b>ELECTRIC</b>																		
EVSE Cable for 10 amp charging using domestic 3-pin plug	-	-	o	-	-	-	o	-	-	-	-	-	-	-	-	o	-	-
Type 2 Mennekes charging cable 32A (IEC - 629196) 6m	-	-	o	-	-	-	o	-	-	-	-	-	-	-	o	-	-	-

●= Standard (therefore no cost) o= Optional - = Not available #Manufacturer's recommended retail prices.

(1) On the Box Van and Low Loader versions, only the base chassis is painted. The box will remain white. If your box is required to be painted, please contact your local dealer to get a quote. (2) For list of compatible Bluetooth devices visit <https://www.renault.co.uk/services/multimedia/bluetooth-compatibility.html> (3) On FWD 135, 150 and 180 versions must be ordered with air conditioning. Not available on Quickshift engines. (4) Only available on 3.5T Chassis Cab single cab, Dropside single cab, Dropside double cab & Panel Vans. Must be ordered with a locking differential and is not available with Power take off, MediaNav, Lane departure warning, Automatic high-low beam or 4.5T versions. Due to the weight of the 4x4 system selecting this option will reduce your payload. (5) Standard on 4.5T versions and the digital tachograph needs to be calibrated by the dealership on hand-over (6) Not available on 4.5T versions (7) Not available on Factory Steel Tipper (8) Increase idle speed and Power take off - gearbox cannot be ordered together (9) Not available on Quickshift versions (10) Only available on Twin RWD Versions (11) Not compatible with ECO Mode and Increased idle speed (12) Not available on twin RWD versions (13) Cannot be ordered with Front passenger airbag or front lateral curtain airbag (14) Standard on Double Cab Factory Tipper and LWB Twin rear wheel Dropsides. Still optional on Aluminium Tipppers (15) Cannot be ordered with Front lateral curtain airbag (16) Not available on RWD (17) Not available on FWD (18) Requires to be taken with Long wiring loom and Battery interface (19) Requires to be taken with B-Pillar wiring connect point (20) Requires Battery interface and CAN interface unit (21) Not compatible with Air suspension (22) Requires Battery interface (23) Not compatible with Stop/Start ENERGY engines (24) Not compatible with All-weather tyres (25) Cannot be ordered with Front parking sensors (26) Not available on 3.1T Z.E. versions

# Renault PRO+, the specialist brand

---



You're the expert in your field and at Renault PRO+ we're here to guide you through ours. We're passionate about delivering products and services to move your business forward. So when you choose to partner with Renault PRO+ you can expect:

## **Specialist network**

Renault PRO+ Centres have a dedicated commercial vehicle specialist. So whatever you're seeking advice on, there's always someone to help.

## **Business Commitment**

Come rain or shine, we have a set of commitments in place to help maximise uptime and minimise downtime.

## **The future today - 100% electric**

Renault PRO+ has been building, selling and maintaining electric vans since 2011. So when you're looking to make the switch, you know who to speak to.

## **A tailored approach**

Your vehicles are as unique as your business. That's why we have a programme of conversions to deliver exactly the product you want. From 'off the shelf' conversions to a more bespoke approach. We'll guide you through.

# Renault services

## 3 Years Warranty

Your vehicle is covered by a warranty package for up to 3 years from date of first registration (unlimited mileage during the first 24 months, followed by a further 1 year limited to a total mileage of 100,000). Your Renault Dealer is able to repair or replace without charge, parts that are found to have a material or assembly defect that is recognised by Renault. The paintwork warranty runs for 3 years and the anti-corrosion warranty for 6 years.

For Warranty Terms and Conditions please visit [www.renault.co.uk/warranty](http://www.renault.co.uk/warranty).

## 3 Years Renault Assistance

Should you need it, we'll provide emergency roadside repairs or tow you to the nearest Renault Dealer. This service is available 24 hours a day and is provided for 36 months from the date of first registration (unlimited mileage for first 24 months, then limited to a total of 100,000 miles or 3 years, whichever comes first). Assistance is provided within the UK & Northern Ireland only at roadside, home and includes national recovery and onward travel. Assistance applies to mechanical or electrical defects which are covered by warranty.

For Renault Assistance Terms and Conditions please visit [www.renault.co.uk/assistance](http://www.renault.co.uk/assistance).

## Service Intervals

MASTER Z.E. Service: Year 1 / 12,000 miles,  
Year 2 / 24,000 miles and then every 2 years / 24,000 miles thereafter

MASTER all other engines and versions: 24,000 miles / 2 years

## Renault Network Services

No-one is better placed than Renault to maintain, fit and repair your Renault, fast. The Renault Minute (maintenance and repair with no appointment necessary) and Renault Rapide Bodycare (bumper scuffs, dings and dents, windscreen, stone chips and interior repairs...) services deliver the highest level of repair and maintenance and offer a full year's guarantee on original Renault parts. Don't forget to have a look at our wide range of additional equipment and accessories!

## Renault iCare

Is an innovative Service, Maintenance & Repair product that supplies Business customers with a fully supported, managed hassle free service and maintenance package.

Renault iCare is a "Pay-As-You-Go" product that insures your vehicle is maintained by Renault technical experts when work is required.

iCare provides the following benefits:

- Full Service, Maintenance & Repair cover in the Renault Dealer Network
  - Tyres can be included within the contract at an additional fixed cost
  - Ancillary equipment can also be included (at an additional fixed monthly cost)
  - Excludes: Damage/Neglect/Abuse/Glass & Bulbs
- A fixed, pre agreed pence per mile rate
- No excess mileage charges at the end of the contract
- No pooled mileage administration
- Minimalise downtime

For more information and to obtain a quote based on your requirements, please speak to your local Renault Business dealer or visit [www.renault.co.uk/icare](http://www.renault.co.uk/icare)

## Customer Relations

Renault knows the value of communicating with its customers and we have established effective ways to keep in touch with you. If, after speaking to your local Renault dealership, you are not completely satisfied, please contact the Renault UK Customer Relations Department on 0344 3350000\* (Mon-Fri 9.00am to 5.30pm, except Weds 10.00am to 5.30pm. Closed on Bank Holidays). You can also visit our website [www.renault.co.uk](http://www.renault.co.uk) or write to us at: Renault UK Ltd, The Rivers Office Park, Denham Way, Maple Cross, Rickmansworth, Hertfordshire, WD3 9YS.

## Finance options\*

There are numerous ways that you can finance your new vehicle with Renault. Whether you are a fleet or a private buyer, Renault Finance allows you to tailor your payment plan to your needs and circumstances.





Continue the Renault **MASTER** experience  
at [www.renault.co.uk](http://www.renault.co.uk)



Although every effort has been made to ensure that the information contained within this brochure is as accurate and up to date as possible, Renault U.K. reserves the right to modify its models without notice, including their characteristics, specifications, equipment and accessories. Brochures inevitably become out of date or inaccurate in some respects, in that such characteristics, specifications equipment, or accessories may be changed after the publication date given below and can differ from the descriptions given or the photos displayed. It is therefore necessary to check with your Renault Dealer before purchasing any product that the characteristics, specifications, equipment or accessories of the vehicle on order are as advertised.

Renault recommends  Castrol

Prodigious Photo credits: J.B. Lemal, P. Curtet, T. Motta, W. Crozes - Mathématique - ©Renault Marketing 3D - Commerce - 7701 380 809 - October 2020.